

NON-SPARKING SAFETY TOOLS

**DAMAN INTERNATIONAL
1032-Sector-A, Pocket-B,
Vasant Kunj,
New Delhi-110070
INDIA**

Tel: 91-11- 40521948,8076477394

E-Mail: [info@ nonsparkingtools.in](mailto:info@nonsparkingtools.in)

: [akm4351 @yahoo.co.in](mailto:akm4351@yahoo.co.in)

Websites : www.non-sparking-tool.com

: www.nonsparkingtools.in

Daman International is duly registered with GST, Director General of Foreign Trade, and all other authorities of Government of India.

We are registered vendors and active suppliers to some of the biggest companies in India including the following:

- 1. Indian Oil Corporation Ltd**
- 2. Hindustan Petroleum Corporation Ltd**
- 3. ONGC Ltd.**
- 4. Gail India Ltd.**
- 5. Oil India Ltd**
- 6. Bharat Petroleum Corporation Limited**
- 7. BHEL**
- 8. Hero Honda Group**
- 9. NTPC Tamil Nadu Energy Ltd**
- 10. Lanco**
- 11. Department of Atomic Energy**
- 12. Petronet**
- 13. Steel Authority of India**

We are suppliers of Non Sparking Tools, Hand tools, etc. to Petroleum Industries, ONGC, Gail, IOCL etc as above

Other Company in our group TMS Pvt. Ltd is supplying following Testing Machines to Indian Railways and Research Laboratories.

- *Ultrasonic Flaw Detectors;**
- *Ultrasonic Probes and Accessories,**
- *Ultrasonic Thickness Gauge;**
- *Ultrasonic Rail Testers.**
- *Electro-Magnetic Crack Detectors (MPI)**
- *MPI Consumables and Accessories.**
- *Hardness Testers (Rockwell, Brinell and Vickers type)**
- *Universal Testing Machine Servo (AC / DC) Driven**
(For Compression / Tension/ Bend/Transverse and Brinell hardness)

All the above products are supported with after-sale-service from our factory trained Service Engineers.

TECHNICAL SPECIFICATIONS OF NON SPARKING TOOLS

ITEM	BE-BRONZE	AL-BRONZE
COMPOSITION	Be : 1.8 - 2.3 %	Al: 10-12%
	Co + Ni: over 0.2 %	Ni: 4-6%
	Co + Ni + Fe: below 1.2 %	Fe+Mn: Below 5.8%
	Cu +Be +Co +Ni +Fe:over 99.0 %	Cu+ Al+ Ni+ Fe+ Mn : Over 99%
HARDNESS (HRC)	30-40	20-30
Tensile Strength	1050N/mm2 ~ 1200 N/mm2	750N/mm2 ~ 850N/mm2

Our Copper Titanium Non sparking Tools CuTi as per Bureau of Indian Standards IS 4595 are also available.

Extra High Strength tools and Special tools as per drawing are made on demand.

Daman International is the pre-eminent supplier and exporter of Non sparking tools, Anti Spark Tools, Spark resistant tools, Spark free tools, Sparkless tools, meeting the demand of all types of industries in India and abroad. The company offers a wide spectrum of non sparking tools that include spanners, hammers, striking wrenches, sockets, screw drivers, chisels, pliers, drum openers, wedges, tool sets, caulking tools etc.

**1/4 " Dr Socket Set – 8Pcs
No.101A**



Number	Contents
101A	Socket 4mm,4.5mm,5mm,5.5mm, 6mm,7mm,8mm Driver Type Handle 55mm

1/4 " Dr Socket Set – 9Pcs
No.101B



Number	Contents
101B	Socket 4mm,5mm,6mm,7mm,8mm, 9mm,10mm,11mm Driver Type Handle 55mm

3/8 " Dr Socket Set – 11Pcs
No.101C



Number	Contents
101C	Socket 10mm.11mm.12mm.13mm. 14mm,17mm,19mm, 13/16" Spark Plug Ratchet Wrench 200mm Straight Joint Driver Extension 75mm

1/4*3/8" Dr Socket Set – 21pcs
No.101D



Number	Contents
101D	1/4"Socket 4mm,4.5mm,5mm, 5.5mm,6mm,7mm,8mm
	Ratchet Wrench 200mm
	Straight Joint
	Driver Extension 75mm,150mm
	3/8"Socket 10mm,11mm,12mm, 13mm,14mm,17mm,19mm
	13/16"Spark Plug
	Adaptor
	Driver Type Handle 55mm

1/2" Dr Socket Set – 9pcs
No.101E



Number	Contents
101E	Socket 10mm,11mm,12mm,14mm, 17mm,19mm,22mm,24mm Offset Handle 230mm

1/2 "Dr Socket Set – 13pcs
No.101F



Number	Contents
101F	Socket 8mm,10mm,11mm,12mm,14mm, 17mm,19mm,22mm,24mm,27mm Ratchet Wrench 245mm Hinged Handle 250mm Socket Case

1/2 "Dr Socket Set –17pcs
No.101G



Number	Contents
101G	Socket 10mm,11mm,12mm,14mm,17mm, 19mm,22mm,24mm,27mm,30mm,32mm Ratchet Wrench 245mm Sliding T-Handle 250mm Speed Handle 400mm Driver Extension 125mm,250mm Socket Case

1/2 "Dr Socket Set – 24pcs

No.101H



Number	Contents
101H	Socket 10mm,11mm,12mm,13mm,14mm, 15mm,16mm,17mm,18mm,19mm,20mm, 21mm,22mm,23mm,24mm,27mm,30mm, 32mm Ratchet Wrench 245mm Sliding T-Handle 250mm Speed Handle 400mm Driver Extension 125mm,250mm Universal Joint 80mm

1/2 "Dr Socket Set – 28pcs

No.101I



Number	Contents
101I	Socket 10mm,11mm,12mm,13mm,14mm, 15mm,16mm,17mm,18mm,19mm,20mm, 21mm,22mm,23mm,24mm,26mm,27mm, 28mm,30mm,32mm Ratchet Wrench 245mm Sliding T-Handle 250mm Speed Handle 400mm Driver Extension 125mm,250mm Universal Joint 80mm Screwdriver Socket 52mm Socket Case

1/2 "Dr Socket Set – 32pcs
No.101J



Number	Contents
101J	Socket 8mm,9mm,10mm,11mm,12mm, 13mm,14mm,15mm,16mm,17mm,18mm, 19mm,20mm,21mm,22mm,23mm,24mm, 26mm,27mm,28mm,30mm,32mm 13/16" Spark Plug Ratchet Wrench 245mm Sliding T-Handle 250mm Speed Handle 400mm Driver Extension 125mm,250mm Universal Joint 80mm Screwdriver Socket 52mm Offset Handle 230mm Socket Case

3/4" Dr Socket Set – 14pcs
No.101K



Number	Contents
101K	Socket 21mm,24mm,27mm,30mm,32mm, 34mm,36mm,38mm,41mm,46mm,50mm Ratchet Wrench 320mm Sliding T-Handle 3/4" *400 Driver Extension 200mm

3/4" Dr Socket Set – 21pcs
No.101L



Number	Contents
101L	Socket 21mm,22mm,23mm,24mm,26mm, 27mm,28mm,29mm,30mm,31mm,32mm, 34mm,36mm,38mm,41mm,46mm,50mm Ratchet Wrench 320mm Sliding T-Handle 3/4"*400 Driver Extension 200mm Socket Case

3/4"* 1" Dr Socket Set – 26pcs
No.101M



Number	Contents
101M	Socket 21mm,22mm,23mm,24mm,26mm, 27mm,28mm,29mm,30mm,31mm,32mm, 34mm,36mm,38mm,41mm,46mm,50mm, 55mm,60mm,65mm Ratchet Wrench 160mm Sliding T-Handle 3/4"*400 Driver Extension 200mm,430mm 3/4"*120mm Flex Ball Joint 3/4"*1"Sliding T-Handle

1 "Dr Socket Set – 18pcs

No.101N



Number	Contents
101N	Socket 30mm ,31mm ,32mm ,34mm ,36mm, 38mm ,41mm ,46mm ,50mm ,55mm ,60mm, 65mm ,70mm ,75mm ,80mm Sliding T-Handle 3/4" *1" Driver Extension 200mm Flex Ball Joint 1" *120mm

Socket

No.102,103,104



No. 102 C=1/4"

Number	S mm	L mm	Be-Cu g	Al-Cu g	Number	S inch	L mm	Be-Cu g	Al-Cu g
102-4	4	25	11	10	102-1002	5/32	25	11	10
102-4.5	4.5	25	11	10	102-1004	3/16	25	11	10
102-5	5	25	12	11	102-1006	7/32	25	11	10
102-5.5	5.5	25	12	11	102-1008	1/4	25	11	10
102-6	6	25	13	12	102-1010	9/32	25	11	10
102-7	7	25	13	12	102-1012	5/16	25	17	15
102-8	8	25	15	14	102-1014	11/32	25	21	20
102-9	9	25	21	20	102-1016	3/8	25	23	21
102-10	10	25	22	20	102-1018	7/16	25	25	23
102-11	11	25	22	20	102-1020	1/2	26	33	30
102-12	12	26	25	22					
102-13	13	26	26	24					
102-14	14	26	27	25					
102-15	15	27	33	30					
102-16	16	27	34	31					
102-17	17	27	35	32					

102-18	18	27	36	33
102-19	19	27	38	35

No.103 C=3/8 "

Number	S mm	L mm	Be-Cu g	Al-Cu g	Number	S inch	L mm	Be-Cu g	Al-Cu g
103-5	5	28	20	18					
103-5.5	5.5	28	21	19	103-1002	5/16	28	22	20
103-6	6	28	22	20	103-1004	3/8	28	31	28
103-7	7	28	22	20	103-1006	7/16	32	39	36
103-8	8	28	23	21	103-1008	1/2	32	40	38
103-9	9	28	24	22	103-1010	9/16	32	46	42
103-10	10	32	39	35	103-1012	5/8	32	70	65
103-11	11	32	40	37	103-1014	11/16	32	72	67
103-12	12	32	41	38					
					103-1016	3/4	32	68	60
103-13	13	32	42	39	103-1018	13/16	35	87	80
103-14	14	32	45	40	103-1020	7/8	35	93	85
103-15	15	32	50	45	103-1022	15/16	35	104	95
103-16	16	32	55	50					
103-17	17	32	59	54					
103-19	19	32	68	60					
103-20	20	32	72	65					

No.104 C=1/2"

Number	S mm	L mm	Be-Cu g	Al-Cu g	Number	S inch	L mm	Be-Cu g	Al-Cu g
104-6	6	40	75	69					
104-7	7	40	77	70	104-1002	5/16	40	70	70
104-8	8	40	77	70	104-1004	3/8	40	78	71
104-9	9	40	78	71	104-1006	7/16	40	79	72
104-10	10	40	78	71	104-1008	1/2	40	80	73
104-11	11	40	79	72	104-1010	9/16	40	80	73
104-12	12	40	79	72	104-1012	5/8	40	88	80
104-13	13	40	80	73	104-1014	11/16	40	93	85
104-14	14	40	80	73	104-1016	3/4	42	110	100
104-15	15	40	82	75	104-1018	13/16	43	125	110
104-16	16	40	85	77	104-1020	7/8	43	130	115
104-17	17	40	88	80	104-1022	15/16	43	165	145
104-18	18	42	90	82	104-1024	1	43	190	170
104-19	19	42	110	100	104-1026	1-1/16	46	215	190
104-20	20	42	120	105	104-1028	1-1/4	46	295	260
104-21	21	43	125	110	104-1030	1-7/16	50	330	300
104-22	22	43	130	115					
104-23	23	43	150	135					
104-24	24	43	165	145					
104-25	25	43	180	160					
104-26	26	43	200	180					
104-27	27	46	215	190					
104-28	28	46	225	200					
104-29	29	46	235	210					
104-30	30	46	250	220					
104-32	32	46	295	260					

**Socket
No.105**



C = 3 / 4"

Number	S mm	L mm	Be-Cu g	Al-Cu g
105 17	17	50	246	225
105 19	19	50	246	225
105 21	21	55	268	245
105 22	22	55	268	245
105 23	23	55	306	280
105 24	24	55	307	280
105 26	26	55	307	280
105 27	27	55	312	285
105 28	28	55	339	310
105 29	29	55	350	320
105 30	30	60	410	370
105 31	31	60	430	380
105 32	32	60	465	410
105 34	34	60	480	440
105 36	36	60	510	465
105 38	38	60	555	510
105 41	41	65	660	640
105 46	46	65	765	690
105 50	50	70	910	825
Number	S inch	L mm	Be-Cu g	Al-Cu g
105-1002	3/4	50	240	220
105-1004	13/16	55	262	240
105-1006	7/8	55	267	245
105-1008	15/16	55	305	280
105-1010	1	55	310	280
105-1012	1-1/16	55	315	285
105-1014	1-1/8	55	345	315
105-1016	1-3/16	60	400	365
105-1018	1-1/4	60	437	400
105-1020	1-5/16	60	472	430
105-1022	1-3/8	60	515	470
105-1024	1-7/16	60	525	480
105-1026	1-1/2	60	580	530
105-1028	1-5/8	65	702	640
105-1030	1-3/4	65	761	695
105-1032	1-13/16	65	830	705
105-1034	1-7/8	65	850	750
105-1036	2	70	965	870

Socket

No.106

C = 1"

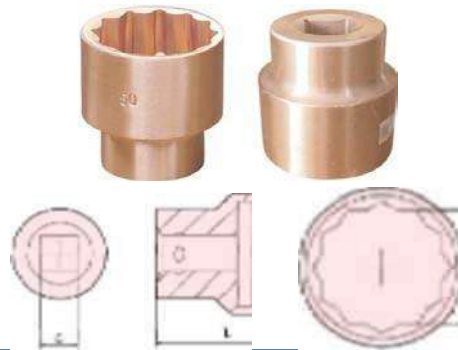

Number	S	L	Be-Cu	Al-Cu
	mm	mm	g	G
106-22	22	55	361	330
106-24	24	55	372	340
106-25	25	55	377	345
106-26	26	55	383	350
106-27	27	55	394	360
106-28	28	55	397	363
106-29	29	55	399	365
106-30	30	60	443	405
106-31	31	60	448	410
106-32	32	60	481	440
106-34	34	60	497	455
106-36	36	65	550	500
106-38	38	65	620	560
106-41	41	70	690	625
106-46	46	75	850	740
106-50	50	75	850	760
106-55	55	80	1160	1000
106-60	60	85	1390	1260
106-65	65	90	1750	1580
106-70	70	90	2150	1950
106-75	75	95	2680	2430
106-80	80	95	2930	2660
Number	S	L mm	Be-Cu	Al-Cu
	inch		g	G
106-1002	1-1/16	55	394	360
106-1004	1-1/8	55	398	364
106-1006	1-3/16	60	442	405
106-1008	1-1/4	60	470	431
106-1010	1-5/16	60	483	442
106-1012	1-3/8	60	490	448
106-1014	1-7/16	65	560	500
106-1016	1-1/2	65	620	560
106-1018	1-5/8	70	690	625
106-1020	1-7/8	75	850	740
106-1022	2	75	960	850
106-1024	2-1/4	80	1250	1130
106-1026	2-1/2	90	1590	1350
106-1028	2-3/4	90	2050	1850
106-1030	3	95	2270	2060

impact Socket



No.107 C=3/4"					No.109 C=1-3/16"				
Number	S mm	L mm	Be-Cu g	Al-Cu g	Number	S mm	L mm	Be-Cu g	Al-Cu g
107-24	24	50	380	330	109-50	50	90	1930	1755
107-27	27	53	405	365	109-52	52	90	2005	1835
107-30	30	53	440	390	109-55	55	90	2180	1965
107-32	32	56	475	425	109-58	58	90	2200	2000
107-36	36	56	650	585	109-60	60	90	2290	2085
107-41	41	60	695	625	109-65	65	90	2610	2370
107-46	46	60	770	700	109-70	70	90	2840	2585
107-50	50	70	1100	1000	109-75	75	90	3190	2880
					109-80	80	90	3605	3250
No.108 C=1"					No.110 C=1-1/4"				
Number	S mm	L mm	Be-Cu g	Al-Cu g	Number	S mm	L mm	Be-Cu g	Al-Cu g
108-19	19	55	630	570	110-50	50	90	1950	1765
					110-60	60	90	2300	2275
					110-70	70	90	2750	2475
108-21	21	55	640	580					
108-22	22	55	650	590					
					No.110A C=1-1/2"				
					Number	S mm	L mm	Be-Cu g	Al-Cu g
108-24	24	55	660	600	110A-55	55	90	2020	1825
108-26	26	55	735	660	110A-60	60	90	2360	2135
108-27	27	55	735	670	110A-65	65	95	2390	2165
108-29	29	60	760	690	110A-70	70	95	2670	2415
108-30	30	60	765	690	110A-75	75	100	3180	2875
108-32	32	60	775	700	110A-80	80	100	3460	3130
108-34	34	60	775	700	110A-85	85	110	3950	3575
108-35	35	60	775	700	110A-90	90	110	4230	3830
108-36	36	60	775	700					
108-38	38	65	865	780					
108-41	41	70	930	830					
108-46	46	75	1380	1265					
108-50	50	75	1455	1320					
108-52	52	75	1715	1550					
108-55	55	75	1830	1650					
108-58	58	85	2080	1900					
108-60	60	85	2200	2000					
108-65	65	85	2460	2250					
108-70	70	90	2890	2600					
108-75	75	90	3155	2900					
108-80	80	90	3560	3200					

Flex Ball Joint

No.111

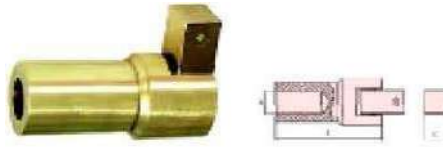

Number	C inch	L mm	Φ mm	Be-Cu g	Al-Cu g
111-1002	3/4	120	21	880	800
111-1004	1	120	21	1160	1050

Internal Hexagon Socket

No.111A



Number	C inch	S Mm	L mm	Be-Cu g	Al-Cu g
111A-1002		3	55	17	16
111A-1004		4	55	17	16
111A-1006		5	55	20	18
111A-1008	1/4	6	55	26	23
111A-1010		7	55	30	27
111A-1012		8	65	45	40
111A-1014		9	65	55	50
111A-1016		10	65	65	60

Socket Wrench, triangular

No.111B

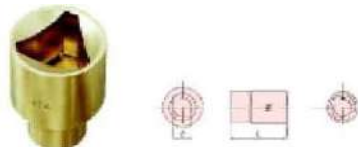

Number	C inch	M mm	L mm	Be-Cu g	Al-Cu g
111B-1002	1/2	6	40	75	70
111B-1004		8	40	80	75
111B-1006		10	40	85	80
111B-1008		12	40	95	90
111B-1010		16	50	180	150
111B-1012		20	50	250	215
111B-1014		24	60	470	436

Spark Plug Socket

No.111C



Number	C inch	S inch	L mm	Be-Cu g	Al-Cu g
111C-1002	3/8	13/16	62	180	160
111C-1004	1/2	13/16	62	180	145

Universal Joint

No.112

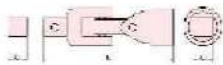

Number	C inch	L mm	Be-Cu g	Al-Cu g
112-1002	1/2	80	186	170
112-1004	3/4	110	530	480
112-1006	1	132	1000	900

Adaptor

No.113

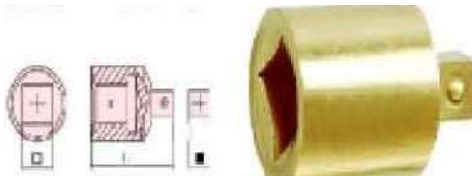

Number	inch	Inch	L mm	Be-Cu g	Al-Cu g
113-1002	3/8	¼	26	22	20
113-1004	1/4	3/8	22	22	20
113-1006	½	3/8	34	80	70
113-1008	3/8	½	34	50	45
113-1010	3/4	½	55	290	260
113-1012	1/2	¾	50	170	150
113-1014	1	¾	70	855	770
113-1016	3/4	1	60	360	320
113-1018	1-1/2	1	85	1675	1510
113-1020	1	1-1/2	85	1230	1100

Screwdriver Socket

No.114

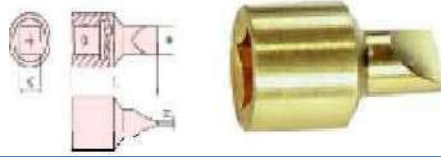

Number	C	L	H	B	Be-Cu	Al-Cu
	inch	mm	mm	mm	g	g
114-1002	1/2	52	2	13	102	91

Ratchet Wrench

No.115



Number	C	L	O	H	Be-Cu	Al-Cu
	inch	mm	mm	mm	g	g
115-1002	3/4	160	21	55	1660	1530
115-1004	1	180	23	60	3270	2960

Sliding T Type Wrench

No.116

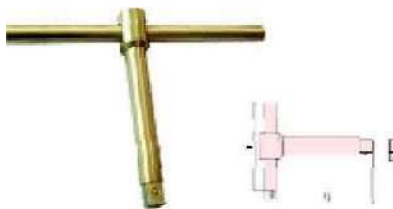

Number	C	L	O	H	Be-Cu	Al-Cu
	inch	mm	mm	mm	g	g
116-1002	3/4	350	19	200	1705	1550
116-1004	1	400	21	200	2590	2350

Sliding T Handle

No.117

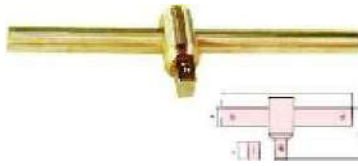

Number	C inch	L mm	H mm	Φ mm	Be-Cu g	Al-Cu g
117-1002	1/2	250	39	13	340	310
117-1004	3/4	350	54	19	1070	960
117-1006	3/4	400	56	21	1335	1221
117-1008	1	400	62	21	1620	1481

Hinged Handle

No.118



Number	C inch	L mm	L1 mm	Be-Cu g	Al-Cu g
118-1002	3/8	190	175	245	220
118-1004	1/2	250	230	440	400
118-1006	1/2	320	300	565	510
118-1008	1/2	400	380	645	580
118-1010	3/4	286	260	635	570
118-1012	1	304	270	910	830

Ratchet Wrench

No.119



Number	C inch	L mm	H mm	Be-Cu g	Al-Cu g
119-1002	1/4	200	16.5	350	305
119-1004	3/8	175	16.5	335	302
119-1006	3/8	200	16.5	400	360
119-1008	1/2	250	16.5	535	480
119-1010	3/4	300	22	1290	1170
119-1012	1	300	22	1590	11480

Ratchet Wrench

No.120



Number	C inch	L mm	H mm	Be-Cu g	Al-Cu g
120-1002	3/8	200	30	290	260
120-1004	1/2	245	43`	690	615
120-1006	3/4	320	57	1570	1430
120-1008	1	550	67	3400	3070

Offset Handle

No.121



Number	C inch	L mm	H mm	Be-Cu g	Al-Cu g
121-1002	3/8	200	50	314	287
121-1004	1/2	230	60	410	380
121-1006	3/4	280	75	765	699
121-1008	1	300	85	1160	1060

**DAMAN INTERNATIONAL INDIA
NON SPARKING TOOLS**

Tel: 91-11-40521948 / 8076477394

E-Mail: akm4351@yahoo.co.in

Wrench, Socket L - Type

No.121A

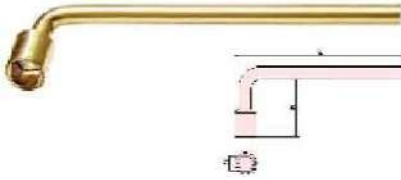

Number	S mm	L mm	H mm	Be-Cu g	Al-Cu g
121A-6	6	120	29	100	35
121A-8	8	145	33	150	60
121A-10	10	168	37	200	90
121A-12	12	216	42	220	135
121A-13	13	240	45	250	190
121A-14	14	245	45	300	215
121A-15	15	250	48	350	240
121A-16	16	255	48	500	290
121A-17	17	260	51	550	325
121A-18	18	265	53	550	365
121A-19	19	270	55	550	400
121A-20	20	272	57	600	450
121A-21	21	275	57	750	550
121A-22	22	278	59	750	645
121A-23	23	282	60	800	680
121A-24	24	286	63	850	700
121A-27	27	294	69	900	800
121A-30	30	302	75	1000	880
121A-32	32	310	81	1100	950
121A-36	36	330	85	1300	1150
121A-41	41	350	90	1380	1410

Sliding T Type Wrench

No.121B



Number	S mm	L mm	H mm	Be-Cu g	Al-Cu g
121B-7	7	120	120	100	90
121B-9	9	130	130	155	140
121B-11	11	140	150	190	170
121B-14	14	150	170	265	240
121B-17	17	170	190	410	370
121B-19	19	180	210	535	480
121B-22	22	190	240	750	680
121B-24	24	200	270	950	860
121B-27	27	200	270	1110	1000
121B-30	30	200	280	1340	1210
121B-32	32	200	280	1440	1300
121B-36	36	200	280	1980	1800

Socket, Double End

No.121C



Number	S1*S2 mm	L mm	H mm	Be-Cu g	Al-Cu g
121C-0607	6*7	105	105	70	65
121C-0809	8*9	115	115	90	80
121C-1011	10*11	120	120	110	120
121C-1213	12*13	140	140	170	160
121C-1415	14*15	140	140	255	230
121C-1617	16*17	155	155	440	340
121C-1819	18*19	165	165	520	460
121C-2022	20*22	175	175	630	570
121C-2123	21*23	185	185	670	600
121C-2427	24*27	195	195	870	785
121C-2528	25*28	205	205	965	870
121C-2730	27*30	210	210	1000	900

Driver Extension

No.122

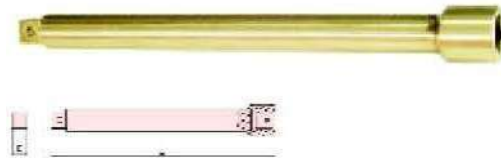

Number	C inch	L mm	Be-Cu g	Al-Cu g
122-1002	3/8	75	93	80
122-1004	3/8	150	185	160
122-1006	1/2	100	245	225
122-1008	1/2	125	260	230
122-1010	1/2	200	365	330
122-1012	1/2	250	470	425
122-1014	3/4	200	855	770
122-1016	1	200	1525	1380

Speed Handle

No.123

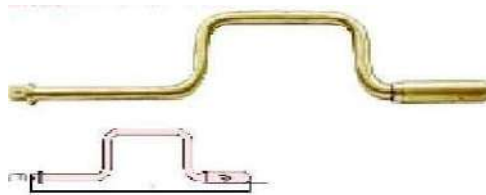

Number	C inch	L mm	H mm	Be-Cu g	Al-Cu g
123-1002	1/2	390	96	780	700

Driver Type handle

No.124

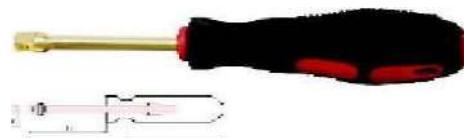

Number	C inch	L Mm	L1 mm	Be-Cu g	Al-Cu g
124 1002	1/4	163	55	62	85

Labor Saving Wrench

No.124A



Number	Size	Be-Cu g	Al-Cu g
124-1002	ZB - 16	2000	1800
124-1004	ZB - 58	6850	6200
124-1006	ZB - 68	8050	7300
124-1008	ZB - 78	8300	7500

Wrench Adjustable

No.125



Number	L mm	Kmax mm	Be-Cu g	Al-Cu g
125-1002	100	13	33	30
125-1004	150	18	135	120
125-1006	200	24	281	255
125-1008	250	30	440	401
125-1010	300	36	720	655
125-1012	375	46	1410	1290
125-1014	450	55	2261	2065
125-1016	600	65	4705	4301

Wrench Adjustable
No.125A



Number	L mm	Kmax mm	Be-Cu g	Al-Cu g
125A-1002	100	13	33	30
125A-1004	150	18	135	120
125A-1006	200	24	281	255
125A-1008	250	30	440	401
125A-1010	300	36	720	655
125A-1012	375	46	1410	1290
125A-1014	450	55	2261	2065
125A-1016	600	65	4705	4301

Wrench, Adjustable
No.125B



Number	L mm	Kmax mm	Be-Cu g	Al-Cu g
125B-1002	100	13	33	30
125B-1004	150	18	135	120
125B-1006	200	24	281	255
125B-1008	250	30	440	401
125B-1010	300	36	720	655
125B-1012	375	46	1410	1290
125B-1014	450	55	2261	2065
125B-1016	600	65	4705	4301

Wrench, Adjustable

No.126



Number	L	Kmax	H	Be-Cu	Al-Cu
	mm	Mm	mm	g	g
126-1002	350	36	80	1384	1251

Wrench, Monkey

No.127

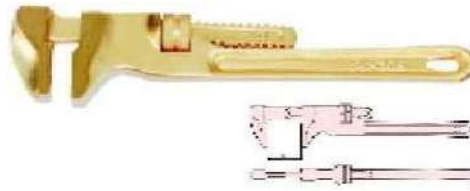

Number	L	Kmax	Be-Cu	Al-Cu
	mm	mm	g	g
127-1002	240	45	510	470
127-1004	254	48	615	560
127-1006	305	58	910	820
127-1008	350	65	1220	1120
127-1010	380	70	1465	1340

Wrench, Swedish Type 45

No.128



Number	L	K	Be-Cu	Al-Cu
	Mm	mm	G	G
128-1002	430	38	1550	1400
128-1004	530	50	2230	2000

Wrench, Swedish Type

No.128A



Number	L mm	D inch	Be-Cu g	Al-Cu g
128A-1002	530	2	2605	2355
128A-1004	650	3	4500	4060
128A-1006	790	4	6200	5600

Pipe Wrench, Swedish Type 90

No.128B



Number	L mm	K mm	Be-Cu g	Al-Cu g
128A-1002	430	38	1480	1330

Wrench, Ch2605ain Pipe

No.129



Number	L mm	Dmax mm	Be-Cu g	Al-Cu g
129-1002	600	100	3955	3605
129-1004	600	150	4650	4200
129-1006	900	200	8600	7800
129-1008	900	300	9810	9000

Wrench, Chain Pipe Light

No.129A



Number	L	Dmax	Be-Cu	Al-Cu
	mm	mm	g	g
129 A-1002	600	100	2105	1910
129A - 1004	1600	450	10500	9500

Wrench, Belt Pipe

No.129B



Number	L	L1	B	Be-Cu	Al-Cu
	mm	Mm	mm	g	g
129B-1002	300	425	30	810	735

Universal Wrench

No.129C



Number	L	D	Be-Cu	Al-Cu
	mm	mm	g	G
129C-1002	250	10 - 30	870	780
129C-1004	450	30 - 60	2450	2200

Wrench, Pipe

No.130



Number	L mm	Kmax mm	Be-Cu g	Al-Cu g
130-1002	200	25	420	380
130-1004	250	30	610	550
130-1006	300	40	787	750
130-1008	350	50	1155	1050
130-1010	450	60	1874	1705
130-1012	600	75	3417	3110
130-1014	900	125	6336	5765
130-1016	1200	150	12894	11410

Wrench, Pipe (American Type)

No.131



Number	L mm	Kmax mm	Be-Cu g	Al-Cu g
131-1002	200	25	460	418
131-1004	250	30	810	738
131-1006	300	40	1158	1050
131-1008	350	50	1450	1318
131-1010	450	60	2485	2260
131-1012	600	75	3820	3470
131-1014	900	85	6482	5890
131-1016	1200	110	13890	12620

Wrench, Pipe (Diagonal Type – 9pcs

No.131B



Number	L mm	Dmax Mm	Be- Cu G	Al- Cu g
131B-1002	200	34	560	510
131B-1004	250	48	930	840
131B-1006	300	50	1470	1330
131B-1008	375	60	1780	1610
131B-1010	450	76	2650	2400

Wrench, Pipe (Bent Type)

- **No.131C**



Number	L	Dmax	Be-Cu	Al-Cu
	mm	mm	G	G
131C-1002	200	34	500	450
131C-1004	250	48	850	780
131C-1006	300	50	1200	1090
131C-1008	375	60	1950	1770
131C-1010	450	76	2730	2480

Wrench, Pipe (Hex Type)

- **No.131D**



Number	L	Dmax	Be-Cu	Al-Cu
	mm	mm	G	G
131D-1002	250	30	1250	1130
131D-1004	350	50	1785	1620

Wrench, Pipe (Bent & Hex Type)

- **No.131E**



Number	L	Dmax	Be-Cu	Al-Cu
	mm	mm	G	G
131E-1002	250	30	1250	1130
131E-1004	350	50	1785	1620

Wrench, Pipe (Bent & Hex Type)

No.131F



Number	L	Dmax	Be-Cu	Al-Cu
	mm	mm	G	G
131F-1002	250	48	980	880
131F-1004	350	60	1900	1710

Wrench, Combination Set – 9pcs

No.132



Number	S	Be-Cu	Al-Cu
	mm	g	g
132	8,10,12,14,17,19, 22,24,27	1815	1655

No.133 Set - 11pcs

Number	S	Be-Cu	Al-Cu
	mm	g	g
133	8,10,12,14,17,19, 22,24,27,30,32	3235	2955

No.134 Set - 13pcs

Number	S	Be-Cu	Al-Cu
	mm	g	g
134	8,10,12,13,14,16,17, 19,22,24,27,30,32	3485	3175

Wrench, Combination

No.135



Number	S mm	L mm	Be-Cu g	Al-Cu g
135-6	6	105	22	20
135-7	7	120	37	34
135-8	8	120	37	34
135-9	9	135	55	50
135-10	10	135	55	50
135-11	11	150	75	75
135-12	12	150	75	70
135-13	13	175	122	110
135-14	14	175	122	110
135-15	15	195	160	145
135-16	16	195	155	140
135-17	17	195	155	140
135-18	18	215	210	190
135-19	19	215	210	190
135-20	20	230	225	200
135-21	21	230	225	200
135-22	22	245	250	220
135-23	23	265	265	233
135-24	24	265	260	230
135-25	25	265	260	230
135-26	26	290	420	380
135-27	27	290	420	380
135-30	30	320	560	500
135-32	32	340	670	600
135-34	34	360	850	750
135-35	35	360	890	800
135-36	36	360	890	800
135-38	38	430	1440	1300
135-41	41	430	1440	1300
135-46	46	480	1890	1700
135-50	50	520	2220	2000
135-55	55	560	2460	2230
135-60	60	595	3300	2950
135-65	65	595	3250	2900
135-70	70	630	4550	4100

Wrench, Combination

No.135A



Number	S mm	L mm	Be-Cu g	Al-Cu g
135A-1002	1/4	105	22	20
135A-1004	5/16	120	37	34
135A-1006	3/8	135	55	50
135A-1008	7/16	150	75	70
135A-1010	1/2	175	125	115
135A-1012	9/16	175	122	110
135A-1014	19/32	195	160	145
135A-1016	5/8	195	155	140
135A-1018	11/16	195	155	140
135A-1020	3/4	215	210	190
135A-1022	13/16	230	225	200
135A-1024	7/8	245	250	225
135A-1026	15/16	265	260	230
135A-1028	1	265	260	230
135A-1030	1-1/16	290	420	380
135A-1032	1-1/8	320	560	500
135A-1034	1-3/16	320	560	500
135A-1036	1-1/4	340	670	600
135A-1038	1-5/16	360	850	750
135A-1040	1-3/8	360	890	800

Wrench, Combination

No.136

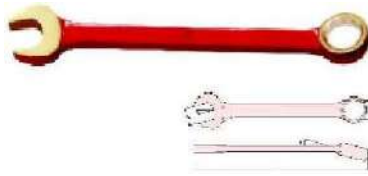

Number	S mm	L mm	Be-Cu g	Al-Cu g
136-6	6	105	18	16
136-7	7	120	40	40
136-8	8	120	40	40
136-9	9	135	45	42
136-10	10	135	45	42
136-11	11	150	65	60
136-12	12	150	65	60
136-13	13	175	90	82
136-14	14	175	90	82
136-15	15	195	140	125
136-16	16	195	140	125
136-17	17	195	140	125
136-18	18	215	180	165
136-19	19	215	180	165
136-20	20	215	180	165
136-21	21	245	280	260
136-22	22	245	280	260
136-23	23	265	320	290
136-24	24	265	320	290
136-25	25	265	500	455
136-26	26	290	500	455
136-27	27	290	500	455
136-30	30	320	700	635
136-32	32	340	780	710
136-34	34	360	1000	910
136-36	36	360	1000	910
136-38	38	430	1450	1310
136-41	41	430	1420	1190
136-46	46	480	1760	1590
136-50	50	520	2020	1830
136-55	55	560	2000	1810
136-60	60	595	2920	2640
136-65	65	595	3430	3110
136-70	70	630	4130	3730
136-75	75	630	4000	3620
136-80	80	660	5400	4880
136-85	85	660	5320	4800
136-90	90	720	7100	6410
136-95	95	720	7000	6250
136-100	100	780	8950	8100
136-110	110	780	10350	9369
136-120	120	900	12750	11560

Wrench, Combination Ratchet

No.136A



Number	S mm	L mm	Be-Cu g	Al-Cu g
136A-17	17	220	250	225
136A-19	19	240	310	280
136A-22	22	270	420	380
136A-24	24	290	570	510
136A-27	27	315	750	675
136A-30	30	350	1000	900
136A-32	32	370	1155	1040

Wrench, Combination

No.136B



Number	S mm	L mm	Be-Cu g	Al-Cu g
136B-17	17	195	161	148
136B19	19	215	210	90
136B-22	22	245	280	260
136B-24	24	265	380	335
136B – 27	27	285	484	444
136B-30	30	310	656	600
136B-32	32	330	770	705
136B-36	36	345	1090	1002
136B-41	41	366	1220	1120
136B-46	46	405	1550	1420
136B-50	50	420	1735	1590
136B-55	55	445	2210	2025
136B-60	60	462	2585	2365
136B-65	65	470	2980	2740

Wrench, Combination

No.137

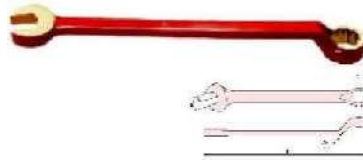

Number	S mm	L mm	Be-Cu g	Al-Cu g
137-17	17	240	230	210
137-19	19	270	280	250
137-21	21	290	380	340
137-22	22	295	440	370
137-24	24	320	460	390
137-27	27	350	605	520

Wrench, Bent Open End

No.138

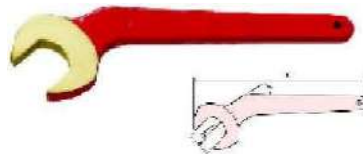

Number	S mm	L mm	Be-Cu g	Al-Cu g
138-12	12	120	55	50
138-14	14	130	90	80
138-17	17	150	125	115
138-19	19	170	180	165
138-22	22	190	250	230
138-24	24	210	255	235
138-27	27	230	380	350
138-30	30	250	490	450
138-32	32	270	590	545
138-34	34	280	720	660
138-36	36	290	850	780
138-41	41	310	1090	1005
138-46	46	330	1340	1225
138-50	50	350	1615	1480
138-55	55	370	2135	1955

Wrench, Construction with Pin

No.139



Number	S mm	L mm	Be-Cu g	Al-Cu g
139-17	17	220	125	115
139-19	19	240	160	145
139-22	22	260	210	190
139-24	24	280	265	240
139-27	27	300	350	315
139-30	30	320	445	405
139-32	32	340	530	480
139-36	36	360	720	650
139-41	41	380	1010	910
139-46	46	400	1115	1010
139-50	50	420	1165	1055
139-55	55	450	1485	1345
139-60	60	480	2015	1825

Wrench, Single Open End

No.140



Number	S mm	L mm	Be-Cu g	Al-Cu g
140 - 8	8	95	40	35
140-10	10	100	50	45
140-12	12	110	65	60
140-14	14	140	95	85
140-17	17	160	105	95
140-19	19	170	130	115
140-22	22	195	170	152
140-24	24	220	190	170
140-27	27	240	285	260
140-30	30	260	320	290
140-32	32	275	400	365
140-34	34	290	455	410
140-36	36	310	530	480
140-41	41	345	615	555
140-46	46	375	950	860
140-50	50	410	1080	950
140-55	55	450	1380	1200
140-60	60	490	1950	1700
140-65	65	530	2250	2000
140-70	70	570	2850	2550
140-75	75	610	3200	2800

Crow Foot Open End

No.140A



Number	C inch	S inch	L mm	Be-Cu g	Al-Cu g	
140A-1002	3/8	9/16	35	55	50	
140A-1004		5/8	37	55	50	
140A-1006		11/16	38	55	50	
140A-1008		7/8	43	60	55	
140A-1010		1-1/8	50	83	75	
140A-1012		1-1/4	53	95	85	
140A-1014		1-3/8	56	103	90	
140A-1016		1-1/2	59	130	120	
140A-1018		1-7/8	72	180	160	
140A-1020		2	75	190	165	
140A-1022		2-1/4	81	200	180	
140A-1024		1/2	14	40	60	55
140A-1026			16	43	62	58
140A-1028	17		43	62	58	
140A-1030	19		49	105	95	
140A-1032	20		49	105	95	
140A-1034	22		52	120	102	
140A-1036	27		59	145	125	

Wrench, Construction, Offset Type With Pin

No.140B



Number	S mm	L mm	Be-Cu g	Al-Cu g
140B-17	17	320	210	195
140B-19	19	350	320	290
140B-22	22	350	430	390
140B-24	24	370	480	430
140B-27	27	370	640	580
140B-30	30	400	800	720
140B-32	32	400	800	720
140B-36	36	430	950	860
140B-41	41	470	1270	1150
140B-46	46	500	1600	1445
140B-50	50	530	1885	1700
140B-55	55	560	2160	1950

T – Handle Wrench

No.140C



Number	S mm	K mm	L mm	Be-Cu g	Al-Cu g
140C-8	8	5	215	135	120
140C-10	10	6	215	140	125
140C-12	12	8	215	145	130
140C-14	14	10	215	150	135

Wrench, Single Open End

No.140D

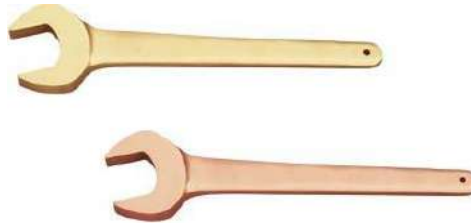

Number	S mm	L mm	Be-Cu g	Al-Cu g
140D-22	22	180	220	180
140D-24	24	196	235	195
140D-27	27	225	330	280
140D-30	30	255	450	390
140D-32	32	275	602	520
140D-36	36	300	901	775
140D-41	41	325	1040	950
140-46	46	350	1180	1080

DAMAN INTERNATIONAL INDIA

NON SPARKING TOOLS

Tel: 91-11-40521948 / 8076477394

E-Mail: akm4351@yahoo.co.in

Wrench, Striking Open

No.141



Number	S mm	L mm	Be-Cu g	Al-Cu g
141-17	17	125	150	135
141-19	19	125	150	135
141-22	22	135	195	175
141-24	24	150	245	220
141-27	27	175	335	300
141-30	30	190	435	390
141-32	32	190	515	460
141-36	36	200	725	655
141-41	41	230	955	860
141-46	46	250	1225	1100
141-50	50	275	1560	1420
141-55	55	305	1850	1680
141-60	60	315	2190	1970
141-65	65	335	3060	2780
141-70	70	370	4030	3660
141-75	75	375	4200	3800
141-80	80	400	5650	5130
141-85	85	400	6000	5400
141-90	90	445	7800	7050
141-95	95	445	7730	7000
141-100	100	485	11600	10500
141-110	110	513	13500	12000

Wrench, Striking Open

No.141A



Number	S mm	L mm	Be-Cu g	Al-Cu g
141A-17	17	130	133	120
141A-19	19	140	172	155
141A-22	22	155	252	230
141A-24	24	165	305	275
141A-27	27	175	385	350
141A-30	30	185	515	470
141A-32	32	195	585	535
141A-36	36	210	851	780
141A-41	41	225	1055	965
141A-46	46	240	1245	1140
141A-50	50	255	1580	1445
141A-55	55	270	1865	1705
141A-60	60	285	2205	2015
141A-65	65	305	3060	2805
141A-70	70	325	3620	3310
141A-75	75	345	3905	3570
141A-80	80	365	4845	4440
141A-90	90	385	5370	4920

Wrench, Bent Striking Open

No.141B



Number	S mm	L mm	Be-Cu g	Al-Cu g
141B-17	17	125	160	150
141B-19	19	125	160	150
141B-22	22	135	180	160
141B-24	24	150	245	220
141B-27	27	175	420	380
141B-30	30	190	480	440
141B-32	32	190	480	440
141B-34	34	200	600	540
141B-36	36	210	680	620
141B-38	38	230	980	800
141B-41	41	230	950	860
141B-46	46	250	1270	1150
141B-50	50	275	1380	1250
141B-55	55	305	1780	1620
141B-60	60	315	2560	2350
141B-65	65	335	3000	2750

Wrench, Double Open End Set-9pcs

No.142

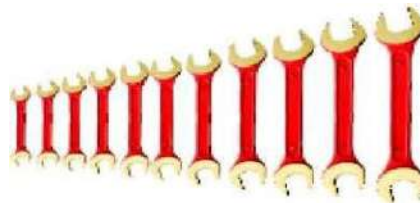

Number	S1*S2 mm	Be-Cu g	Al-Cu g
142	8*10,10*12,12*14, 14*17,17*19,19*22, 22*24,24*27,30*32	2810	2570

Set - 11pcs

No.143

Number	S1*S2 mm	Be-Cu g	Al-Cu g
143	8*10,9*11,10*12,12*14, 14*17,17*19,19*22, 22*24,24*27,27*30,30*32	3530	3230

Set – 13pcs**No.144**

Number	S1*S2 mm	Be-Cu g	Al-Cu g
144	5.5*7,6*7,8*10,9*11, 10*12,12*14,14*17, 17*19,19*22,22*24, 24*27,27*30,30*32	3610	3295

Wrench, Double Open End**No.145**

Number	S1*S2 mm	L mm	Be-Cu g	Al-Cu g
145-0607	6*7	92	40	35
145-0709	7*9	96	45	40
145-0810	8*10	100	60	55
145-0911	9*11	110	75	70
145-1012	10*12	120	95	87
145-1214	12*14	130	145	133
145-1417	14*17	150	180	165
145-1719	17*19	170	235	215
145-1922	19*22	185	330	302
145-2224	22*24	210	445	430
145-2427	24*27	230	535	490
145-2730	27*30	250	650	593
145-3032	30*32	265	775	710
145-3036	30*36	270	925	845
145-3234	32*34	275	1055	965
145-32*36	32*36	290	1155	1055
145-34*36	34*36	305	1475	1350
145-3641	36*41	335	1610	1470
145-4146	41*46	355	1790	1640
145-4650	46*50	370	2220	2030
145-5055	50*55	385	2610	2385
145-5060	50*60	400	3085	2820
145-5560	55*60	415	3270	2990
145-6065	60*65	435	4540	4150
145-6570	65*70	460	6130	5605

Wrench, Double Open End

No.146



Number	S1*S2 mm	L mm	Be-Cu g	Al-Cu g
146-0507	5.5*7	90	23	20
146-0607	6*7	92	25	22
146-0709	7*9	96	28	25
146-0810	8*10	100	34	31
146-0911	9*11	110	50	45
146-1011	10*11	115	52	47
146-1012	10*12	120	60	55
146-1014	10*14	124	68	62
146-1213	12*13	128	73	67
146-1214	12*14	130	75	69
146-1317	13*17	140	110	100
146-1415	14*15	143	115	105
146-1417	14*17	150	120	110
146-1617	16*17	157	130	120
146-1618	16*18	163	145	130
146-1719	17*19	170	150	135
146-1721	17*21	173	185	165
146-1819	18*19	179	200	180
146-1921	19*21	182	210	190
146-1922	19*22	185	220	200
146-1924	19*24	190	235	210
146-2022	20*22	195	250	225
146-2123	21*23	200	270	235
146-2126	21*26	205	275	245
146-2224	22*24	210	312	285
146-2227	22*27	215	320	292
146-2326	23*26	220	330	302
146-2427	24*27	230	345	310
146-2430	24*30	233	365	330
146-2528	25*28	236	365	330
146-2632	26*32	243	465	420
146-2730	27*30	250	485	430
146-2732	27*32	255	600	549
146-3032	30*32	265	610	540
146-3036	30*36	270	815	730
146-3234	32*34	270	815	730
146-3236	32*36	300	885	800
146-3436	34*36	300	885	800
146-3638	36*38	330	1350	1210
146-3641	36*41	330	1350	1210
146-3840	38*40	330	1350	1210
146-4146	41*46	355	1590	1430
146-4650	46*50	370	2050	1850
146-5055	50*55	385	2160	1950
146-5060	50*60	400	2488	2275
146-5560	55*60	415	2700	2450
146-6065	60*65	435	3950	3600

Wrench, Double Open End

No.146A



Number	S1*S2 mm	L mm	Be-Cu g	Al-Cu g
146A-1002	14*17	160	110	100
146A-1004	17*19	180	120	110
146A-1006	19*22	200	160	140
146A-1008	19*24	220	180	160
146A-1010	22*24	230	240	220
146A-1012	24*27	255	340	305
146A-1014	27*30	280	420	380
146A-1016	30*32	300	530	480
146A-1018	32*36	320	635	570
146A-1020	34*36	330	740	670
146A-1022	36*41	350	900	810
146A-1024	41*46	380	1060	955
146A-1026	46*50	420	1310	1190
146A-1028	50*55	460	1900	1720
146A-1030	55*60	500	2800	2530

Wrench, Double Open End

No.147



Number	S1*S2 mm	L mm	Be-Cu g	Al-Cu g
147-1002	1/4*5/16	90	34	30
147-1004	5/16*3/8	100	45	40
147-1006	3/8*7/16	110	60	55
147-1008	3/8*1/2	115	68	60
147-1010	7/16*1/2	120	85	78
147-1012	1/2*9/16	130	90	80
147-1014	9/16*5/8	150	120	105
147-1016	5/8*11/16	160	155	130
147-1018	5/8*3/4	165	160	135
147-1020	11/16*3/4	170	170	145
147-1022	3/4*13/16	180	225	185
147-1024	3/4*7/8	185	230	200
147-1026	13/16*7/8	190	240	215
147-1028	7/8*15/16	210	305	270
147-1030	15/16*1	220	365	305
147-1032	1*1-1/16	230	405	355
147-1034	1-1/16*1-1/8	235	450	380
147-1036	1-1/8*1-3/16	245	548	480
147-1038	1-3/16*1-1/4	250	600	525

Wrench, Double Box Offset Set-9pcs

No.148



Number	S1*S2 mm	Be-Cu g	Al-Cu g
148	8*10,10*12,12*14, 14*17,17*19,19*22, 22*24,24*27,30*32	2815	2575

Set – 11pcs

No.149

Number	S1*S2 mm	Be-Cu g	Al-Cu g
149	8*10,9*11,10*12, 12*14,14*17,17*19, 19*22,22*24,24*27, 27*30,30*32	3585	3275

Set – 13pcs

No.150

Number	S1*S2 mm	Be-Cu g	Al-Cu g
150	5.5*7,6*7,8*10,9*11, 10*12,12*14,14*17, 17*19,19*22,22*24, 24*27,27*30,30*32	3630	3320

**DAMAN INTERNATIONAL INDIA
NON SPARKING TOOLS**

Tel: 91-11-40521948 /8076477394

E-Mail: akm4351@yahoo.co.in

Wrench, Double Box Offset
No.151



Number	S1*S2 mm	L mm	Be-Cu g	Al-Cu g
151-0507	5.5*7	115	22	20
151-0607	6*7	115	25	23
151-0709	7*9	130	50	46
151-0810	8*10	130	55	50
151-0911	9*11	140	70	65
151-1011	10*11	140	80	75
151-1012	10*12	140	85	78
151-1213	12*13	160	120	110
151-1214	12*14	160	151	140
151-1417	14*17	220	205	180
151-1618	16*18	220	220	202
151-1719	17*19	250	225	205
151-1722	17*22	250	290	265
151-1819	18*19	250	295	270
151-1922	19*22	280	310	280
151-1924	19*24	310	355	320
151-2123	21*23	285	405	360
151-2126	21*26	320	450	410
151-2224	22*24	310	455	415
151-2427	24*27	340	520	475
151-2430	24*30	350	550	501
151-2528	25*28	350	580	530
151-2632	26*32	370	640	570
151-2730	27*30	360	705	645
151-3032	30*32	380	805	736
151-3036	30*36	395	1050	960
151-3234	32*34	400	1080	980
151-3236	32*36	405	1145	1030
151-3436	34*36	420	1165	1065
151-3641	36*41	445	1600	1465
151-4146	41*46	470	2077	1905
151-4650	46*50	490	2530	2315
151-5055	50*55	510	2580	2360
151-5060	50*60	520	3002	2745
151-5560	55*60	530	3203	2905
151-6070	60*70	560	4105	3605

Wrench, Double Box Offset

No.151A



Number	S1*S2 mm	L mm	Be-Cu g	Al-Cu g
151A-1719	17*19	280	180	160
151A-1922	19*22	300	210	190
151A-1924	19*24	320	320	290
151A-2123	21*23	320	370	335
151A-2224	22*24	330	420	380
151A-2427	24*27	340	480	430
151A-2730	27*30	350	530	480
151A-3032	30*32	370	690	620
151A-3236	32*36	430	1000	910
151A-3641	36*41	470	1270	1150
151A-4146	41*46	500	1580	1430
151A-4650	46*50	525	1900	1720
151A-5055	50*55	550	2850	2580

Wrench, Double Box Offset

No.152



Number	S1*S2 mm	L mm	Be-Cu g	Al-Cu g
152-0507	5.5*7	120	40	35
152-0607	6*7	122	45	40
152-0709	7*9	126	50	46
152-0810	8*10	130	55	50
152-0910	9*10	135	60	55
152-0911	9*11	140	70	65
152-1012	10*12	160	85	80
152-1013	10*13	164	90	85
152-1014	10*14	168	110	100
152-1113	11*13	172	110	105
152-1213	12*13	176	120	115
152-1214	12*14	180	125	110
152-1417	14*17	220	190	170
152-1618	16*18	240	230	205
152-1719	17*19	250	240	215
152-1819	18*19	268	295	270
152-1922	19*22	280	322	295
152-2022	20*22	292	365	330
152-2123	21*23	298	393	360
152-2224	22*24	310	450	415
152-2326	23*26	325	465	435
152-2427	24*27	340	520	476
152-2528	25*28	346	580	530
152-2730	27*30	360	705	645
152-3032	30*32	380	805	736
152-3234	32*34	398	890	800
152-3436	34*36	418	1070	960
152-3638	36*38	434	1200	1080
152-3641	36*41	450	1560	1400
152-4146	41*46	470	1840	1650
152-4650	46*50	490	2530	2314
152-5055	50*55	510	2580	2360

Wrench, Double Box Offset
No.152A



Number	S1*S2 mm	L mm	Be-Cu g	Al-Cu g
152A-0607	6*7	90	45	40
152A-0709	7*9	90	55	50
152A-0810	8*10	100	80	70
152A-0911	9*11	100	90	80
152A-1012	10*12	110	125	110
152A-1214	12*14	125	160	140
152A-1417	14*17	140	230	200
152A-1719	17*19	170	310	270
152A-1922	19*22	185	420	370
152A-1924	19*24	185	450	400
152A-2123	21*23	185	490	430
152A-2126	21*26	185	500	435
152A-2224	22*24	210	670	600
152A-2326	23*26	210	670	600
152A-2427	24*27	225	720	640
152A-2430	24*30	225	740	650
152A-2528	25*28	225	750	670
152A-2730	27*30	250	870	780
152A-3032	30*32	275	1100	980

Wrench, Double Box Offset

No.153



Number	S1*S2 mm	L mm	Be-Cu g	Al-Cu g
153-1002	1/4*5/16	115	30	27
153-1004	5/16*3/8	125	45	40
153-1006	3/8*7/16	140	60	55
153-1008	7/16*1/2	155	90	80
153-1010	1/2*9/16	175	115	105
153-1012	9/16*5/8	215	190	170
153-1014	5/8*11/16	220	205	190
153-1016	11/16*3/4	245	235	215
153-1018	3/4*13/16	255	295	270
153-1020	13/16*7/8	275	350	320
153-1022	7/8*15/16	305	405	370
153-1024	15/16*1	310	490	375
153-1026	1*1-1/16	330	535	490
153-1028	1-1/16*1-1/8	330	570	520
153-1030	1-1/8*1-3/16	370	830	760
153-1032	1-3/16*1-1/4	370	835	765
153-1034	1-1/4*1-5/16	380	1020	935
153-1036	1-5/16*1-3/8	410	1050	960
153-1038	1-3/8*1-7/16	410	1425	1310
153-1040	1-7/16*1-5/8	450	1585	1450
153-1042	1-1/2*1-9/16	460	1803	1640
153-1044	1-5/8*1-13/16	470	2077	1905
153-1046	1-13/16*2	490	2530	2315
153-1048	2*2-3/16	510	2580	2360
153-1050	2*2-3/8	520	3002	2745
153-1052	2-3/16*2-3/8	530	3203	2905
153-1054	2-3/8*2-3/4	560	4105	3605

Wrench, Double Flat Box

No.153A



Number	S1*S2 mm	L mm	Be-Cu g	Al-Cu g
153A-0810	8*9	115	32	29
153A-0911	9*11	125	37	34
153A-1012	10*12	140	55	48
153A-1214	12*14	145	70	62
153A-1417	14*17	165	100	90
153A-1719	17*19	185	132	120
153A-1922	19*22	200	180	165
153A-2224	22*24	220	240	215
153A-2427	24*27	255	320	280
153A-2730	27*30	280	385	340
153A-3032	30*32	295	465	415
153A-3036	30*36	330	600	685
153A-3641	36*41	365	935	845

DAMAN INTERNATIONAL INDIA

NON SPARKING TOOLS

Tel: 91-11-40521948 / 8076477394

E-Mail: akm4351@yahoo.co.in

Flare Nut Open Ring Wrenches

No.153B



Number	S1*S2 mm	L mm	Be-Cu g	Al-Cu g
153B-0607	6*7	95	17	15
153B-0810	8*10	115	32	29
153B-0911	9*11	125	37	34
153B-1012	10*12	140	55	48
153B-1214	12*14	145	70	62
153B-1415	14*15	155	90	80
153B-1417	14*17	165	100	90
153B-1618	16*18	170	127	115
153B-1719	17*19	185	132	120
153B-1922	19*22	200	180	165
153B-2224	22*24	220	240	215
153B-2427	24*27	255	320	288
153B-2430	24*30	270	375	340
153B-2528	25*28	265	380	345
153B-2730	27*30	280	430	389
153B-3032	30*32	295	498	450
153B-3034	30*34	310	588	535
153B-3036	30*36	330	657	595
153B-3436	34*36	345	758	685
153B-3641	36*41	365	935	845

Wrench, Construction

No.154

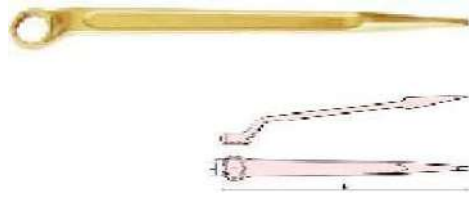

Number	S mm	L mm	Be-Cu g	Al-Cu g
154-10	10	230	90	85
154-12	12	250	110	105
154-14	14	270	145	130
154-17	17	310	200	180
154-19	19	330	250	225
154-22	22	350	320	290
154-24	24	370	400	360
154-27	27	400	500	450
154-30	30	430	700	630
154-32	32	430	660	600
154-36	36	460	900	800
154-41	41	490	1090	990
154-46	46	520	1560	1420
154-50	50	540	1700	1550
154-55	55	560	2050	1850
154-60	60	610	2850	2550

Wrench, Construction

No.155

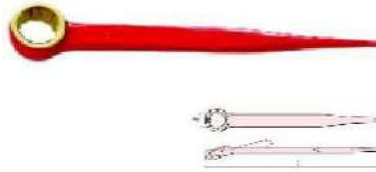

Number	S mm	L mm	Be-Cu g	Al-Cu g
155-8	8	140	60	55
155-10	10	150	70	64
155-11	11	160	80	73
155-12	12	170	90	83
155-13	13	180	102	91
155-14	14	190	115	102
155-15	15	200	125	110
155-16	16	210	130	122
155-17	17	220	165	145
155-18	18	230	180	165
155-19	19	240	230	195
155-20	20	250	242	220
155-21	21	260	251	230
155-22	22	270	303	274
155-23	23	280	330	302
155-24	24	290	361	330
155-27	27	320	472	430
155-30	30	350	650	585
155-32	32	370	680	620
155-34	34	380	803	730
155-36	36	390	950	850
155-38	38	400	1005	880
155-41	41	410	1430	1025
155-46	46	420	1460	1310
155-50	50	430	1580	1420
155-55	55	440	1870	1690
155-60	60	460	2330	2095
155-65	65	480	2802	2535
155-70	70	500	3150	2845

Wrench, Single Box

No.156



Number	S mm	L mm	Be-Cu g	Al-Cu g
156-8	8	110	40	35
156-10	10	120	50	45
156-12	12	130	65	60
156-14	14	140	90	80
156-17	17	155	105	90
156-19	19	170	130	95
156-22	22	190	175	150
156-24	24	215	220	200
156-27	27	230	270	245
156-30	30	255	370	335
156-32	32	265	425	385
156-36	36	295	550	500
156-41	41	330	825	750
156-46	46	365	1120	1010
156-50	50	400	1270	1150
156-55	55	445	1590	1440
156-60	60	474	1850	1680
156-65	65	510	2060	1875
156-70	70	555	2530	2300
156-75	75	590	2700	2450

Wrench, Single Bent Box
No.157

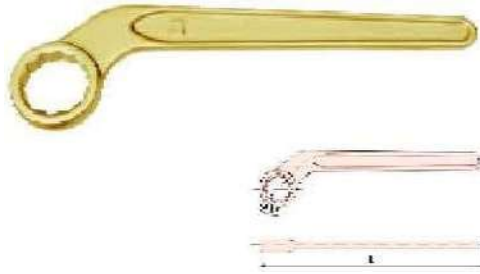

Number	S mm	L mm	Be-Cu g	Al-Cu g
157-10	10	119	60	50
157-12	12	151	85	75
157-14	14	151	85	75
157-16	16	174	150	130
157-17	17	174	160	145
157-19	19	207	195	190
157-22	22	207	205	180
157-24	24	250	330	295
157-27	27	250	315	275
157-30	30	295	480	430
157-32	32	295	455	410
157-34	34	307	650	580
157-36	36	307	650	580
157-38	38	340	830	740
157-41	41	340	810	720
157-46	46	370	1230	1100
157-50	50	400	1400	1255
157-55	55	430	1930	1720
157-60	60	450	2100	1900
157-65	65	470	2360	2135
157-70	70	490	3080	2800
157-75	75	510	3600	3250
157-80	80	530	4460	4030

Wrench, Single Box Offset

No.158



Number	S mm	L mm	Be-Cu g	Al-Cu g
158-17	17	150	135	122
158-19	19	170	175	150
158-21	21	183	220	190
158-22	22	190	230	202
158-24	24	210	302	250
158-27	27	230	380	330
158-30	30	250	505	430
158-32	32	270	620	540
158-36	36	290	805	710

Wrench, Single Box Convex

No.159



Number	S mm	L mm	Be-Cu g	Al-Cu g
159-10	10	110	75	65
159-12	12	120	115	102
159-14	14	130	135	120
159-17	17	150	145	130
159-19	19	170	185	160
159-22	22	190	240	215
159-24	24	210	320	290
159-27	27	230	401	370
159-30	30	250	520	475
159-32	32	270	650	595
159-34	34	280	780	715
159-36	36	290	802	730

Wrench, Single Box Offset
No.159A

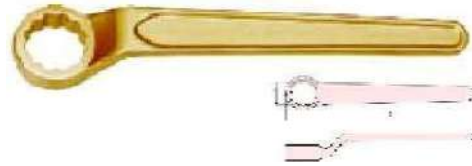

Number	S mm	L mm	Be-Cu g	Al-Cu g
159A-22	22	190	185	165
159A-24	24	215	235	210
159A-27	27	230	310	270
159A-30	30	255	430	380
159A-32	32	265	450	400
159A-36	36	295	610	540
159A-41	41	330	855	770
159A-46	46	365	1000	900
159A-50	50	400	1350	1200
159A-55	55	445	2000	1800
159A-60	60	474	2260	2050
159A-65	65	510	2800	2500
159A-70	70	555	3250	2900
159A-75	75	590	3450	3090

DAMAN INTERNATIONAL INDIA
NON SPARKING TOOLS
Tel: 91-11-40521948 / 8076477394
E-Mail: akm4351@yahoo.co.in

Wrench, Striking Box

No.160



Number	S mm	L mm	Be-Cu g	Al-Cu g
160-17	17	145	210	190
160-19	19	145	200	180
160-22	22	155	245	220
160-24	24	165	235	210
160-27	27	175	350	315
160-30	30	185	475	430
160-32	32	185	465	420
160-34	32	200	540	490
160-36	36	205	580	520
160-38	38	215	680	620
160-41	41	225	755	680
160-46	46	235	990	890
160-50	50	250	1145	1030
160-55	55	265	1440	1300
160-60	60	274	1620	1450
160-65	65	298	1995	1800
160-70	70	320	2435	2200
160-75	75	326	3010	2720
160-80	80	350	3600	3250
160-85	85	355	4330	3915
160-90	90	380	5200	4700
160-95	95	390	5450	4920
160-100	100	410	6750	6100
160-105	105	420	7000	6320
160-110	110	445	9130	8250
160-120	120	480	11000	9930
160-130	130	510	12610	11400
160-140	140	520	13000	11750
160-150	150	565	14500	13100

Wrench, Striking Box

No.160A

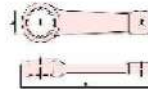

Number	S mm	L mm	Be-Cu g	Al-Cu g
160A-17	17	108	105	95
160A-19	19	117	135	125
160A-22	22	127	192	185
160A-24	24	138	270	250
160A-27	27	150	350	320
160A-30	30	163	460	420
160A-32	32	177	610	555
160A-34	34	192	690	630
160A-36	36	208	780	710
160A-38	38	215	875	805
160A-41	41	225	985	902
160A-46	46	243	1275	1160
160A-50	50	254	1545	1410
160A-55	55	264	1720	1560
160A-60	60	275	2080	1880
160A-65	65	286	2440	2202
160A-70	70	298	2735	2470
160A-75	75	311	3190	2905
160A-80	80	325	3485	3160
160A-85	85	339	3990	3650
160A-90	90	355	4350	3960
160A-95	95	370	5046	4560
160A-100	100	387	5630	5125
160A-105	105	405	6250	5690
160A-110	110	410	6750	6100
160A-120	120	425	7405	6735
160A-130	130	450	7905	7205
160A-140	140	465	8105	7405

Safety Handrail for Striking Wrench

No.160B



Number	Φ mm	L mm	Copper g	Brass g
160B-1002	30	500	1000	950

Wrench, Striking Box

No161

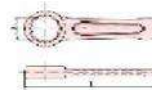

Number	S inch	L mm	Be-Cu g	Al-Cu g
161-1002	11/16	145	210	190
161-1004	3/4	145	200	180
161-1006	7/8	155	245	220
161-1008	1	175	350	315
161-1010	1-1/16	175	350	315
161-1012	1-1/8	185	455	410
161-1014	1-3/16	185	475	430
161-1016	1-1/4	185	470	425
161-1018	1-3/8	200	560	500
161-1020	1-1/2	215	790	710
161-1022	1-5/8	225	755	680
161-1024	1-3/4	235	1020	920
161-1026	1-13/16	235	990	890
161-1028	2	250	1145	1030

Wrench, Striking Box

No.162



Number	S mm	L mm	Be-Cu g	Al-Cu g
162-32	32	180	790	710
162-36	36	190	990	900
162-41	41	200	1450	1300
162-46	46	210	1770	1600
162-50	50	230	1930	1730
162-55	55	260	3400	3060
162-60	60	290	4200	3800
162-65	65	320	5430	4900
162-70	70	350	6480	5850
162-75	75	380	7890	7130
162-80	80	410	10350	9350

**Wrench, Offset Striking Box
No.162A**



Number	S mm	L mm	Be-Cu g	Al-Cu g
162A-27	27	245	670	600
162A-30	30	270	970	870
162A-32	32	270	970	870
162A-36	36	280	1060	950
162A-41	41	305	1430	1280
162A-46	46	310	1830	1640
162A-50	50	320	2100	1890
162A-55	55	320	2350	2110
162A-60	60	355	2900	2610
162A-65	65	380	3470	3120
162A-70	70	400	4050	3640
162A-75	75	420	4350	4180
162A-80	80	435	5500	4950
162A-85	85	440	6500	5820
162A-90	90	445	6820	6320
162A-95	95	450	7880	7000
162A-100	100	455	7900	7130
162A-110	110	460	8400	7590
162A-120	120	470	8900	8040

**DAMAN INTERNATIONAL INDIA
NON SPARKING TOOLS
Tel: 91-11-40521948 / 8076477394
E-Mail: akm4351@yahoo.co.in**

Wrench, Offset Striking Box

No.162B



Number	S mm	L mm	Be-Cu g	Al-Cu g
162B-24	24	160	370	335
162B-27	27	180	475	430
162B-30	30	200	615	555
162B-32	32	200	615	555
162B-36	36	220	825	745
162B-41	41	240	950	860
162B-46	46	250	1330	1200
162B-50	50	270	1650	1450
162B-55	55	295	2000	1800
162B-60	60	317	2430	2200
162B-65	65	330	2750	2490
162B-70	70	350	3385	3060
162B-75	75	370	4655	4205
162B-80	80	385	5020	4540

Wrench, Striking Convex Box

No.163



Number	S mm	L mm	Be-Cu g	Al-Cu g
163-22	22	165	230	210
163-24	24	165	220	300
163-27	27	175	370	335
163-30	30	185	530	480
163-32	32	185	475	430
163-36	36	210	740	670
163-41	41	227	950	860
163-46	46	245	1270	1145
163-50	50	257	1590	1435
163-55	55	267	1800	1625
163-60	60	278	2115	1910
163-65	65	298	2580	2340
163-70	70	320	2960	2680
163-75	75	326	3350	3000

Offset Slogging Box Wrench (American Type)

No.163A

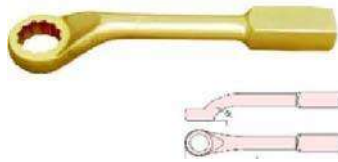

Number	S mm	L mm	Be-Cu g	Al-Cu g
163A-24	24	240	950	860
163A-27	27	270	1150	1035
163A-30	30	280	1480	1340
163A-32	32	290	1690	1530
163A-36	36	300	1900	1720
163A-41	41	320	2110	1910
163A-46	46	340	2750	2485
163A-50	50	350	3170	2870
163A-55	55	360	4125	3730
163A-60	60	375	4335	3920
163A-65	65	390	4440	4010
163A-70	70	400	5400	4875
163A-75	75	420	5810	5255
163A-80	80	440	7295	6600
163A-90	90	480	9740	8800
163A-100	100	515	11300	10200
163A-110	110	550	13400	12100
163A-120	120	585	15500	14000
163A-130	130	620	17700	16000

Wrench, Striking Box Bent

No.164

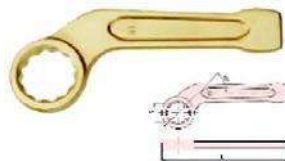

Number	S mm	L mm	Be-Cu g	Al-Cu g
164-24	24	160	280	240
164-27	27	175	370	335
164-30	30	190	525	475
164-32	32	190	500	450
164-36	36	210	630	570
164-41	41	225	750	650
164-46	46	240	1160	1030
164-50	50	255	1240	1100
164-55	55	270	1450	1285
164-60	60	285	1820	1640
164-65	65	300	2645	2390
164-70	70	320	2960	2675

Ring Wrench for extension

No.164A

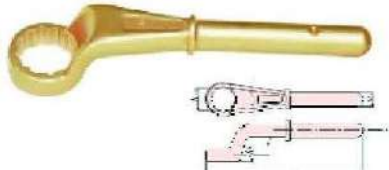

Number	S mm	L mm	Be-Cu g	Al-Cu g
164A-24	24	180	475	430
164A-27	27	190	530	480
164A-30	30	200	580	525
164A-32	32	235	795	715
164A-36	36	245	900	815
164A-41	41	265	1060	955
164A-46	46	280	1480	1340
164A-50	50	290	1690	1530
164A-55	55	300	1850	1670
164A-60	60	345	2960	2670
164A-65	65	355	3380	3055
164A-70	70	365	3910	3530
164A-75	75	375	4335	3920
164A-80	80	385	5180	4680

Extension

No.164A



Number	Φ mm	L mm	Be-Cu g	Al-Cu g
24-30	19	460	940	850
32-41	22	610	1640	1480
46-55	25	760	2480	2240
60-80	30	860	3890	3515

Extension

No.164A



Number	Φ mm	L mm	Be-Cu g	Al-Cu g
24-30	19	460	880	830
32-41	22	610	1280	1210
46-55	25	760	2125	2005
60-80	30	860	3265	3080

Crow Foot Box End

No.164B

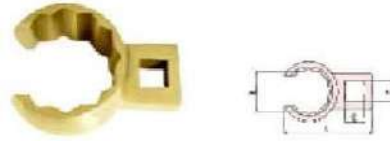

Number	C inch	S inch	L mm	Be-Cu g	Al-Cu g
164B-1002	3/8	7/16	29	35	30
164B-1004		1/2	31	40	35
164B-1006		9/16	33	45	40
164B-1008		5/8	38	50	45
164B-1010		11/16	41	55	50
164B-1012		3/4	43	55	50
164B-1014	1/2	7/8	48	80	70
164B-1016		1	52	85	75
164B-1018		1-1/16	54	90	80
164B-1020		1-1/8	56	100	90
164B-1022		1-1/4	62	145	130
164B-1024		1-5/16	66	170	150
164B-1026		1-1/2	72	190	170
164B-1028		1-5/8	76	210	180
164B-1030		2	89	230	200

Valve Square Driver

No.165



Number	C mm	L mm	H mm	Be-Cu g	Al-Cu g
165-6	6	110	9	65	55
165-8	8	120	10	75	61
165-9	9	140	11	90	75
165-10	10	140	12	105	85
165-11	11	160	13	130	102
165-12	12	190	14	180	145
165-13	13	200	15	185	151
165-14	14	250	16	300	261
165-16	16	250	18	335	285
165-17	17	300	19	420	366
165-19	19	350	20	740	662
165-22	22	400	22	1000	896

Wrench, Hex Key

No.166



Number	S mm	L mm	H mm	Be-Cu g	Al-Cu g
166-1.5	1.5	38	13	6	5
166-2	2	38	13	6	5
166-2.5	2.5	38	13	6	5
166-3	3	59	25	8	7
166-4	4	65	30	10	8
166-5	5	79	32	16	12
166-6	6	85	37	25	20
166-7	7	88	43	34	30
166-8	8	92	44	50	45
166-9	9	97	44	61	55
166-10	10	110	45	82	70
166-11	11	119	48	100	90
166-12	12	130	52	145	130
166-13	13	140	54	180	160
166-14	14	150	58	211	191
166-15	15	156	60	260	230
166-16	16	162	63	300	270
166-17	17	168	65	370	335
166-18	18	173	69	450	402
166-19	19	177	72	490	445
166-21	21	184	74	652	595
166-22	22	186	77	675	615
166-24	24	192	82	825	755
166-25	25	200	84	925	840
166-26	26	206	90	1025	940
166-27	27	213	93	1220	1115
166-28	28	222	95	1350	1235
166-30	30	240	105	1615	1475
166-32	32	266	116	2065	1885
166-36	36	294	128	2905	2650
166-41	41	320	140	4120	3760

**Wrench, Hex Key
No.167**



Number	S inch	L mm	H mm	Be-Cu g	Al-Cu g
167-1002	1/16	38	13	6	5
167-1004	5/64	38	13	6	5
167-1006	3/32	38	13	6	5
167-1008	7/64	58	24	8	5
167-1010	1/8	58	24	8	6
167-1012	9/64	64	29	8	7
167-1014	5/32	65	30	10	9
167-1016	3/16	79	31	15	14
167-1018	7/32	85	37	20	18
167-1020	¼	85	37	30	27
167-1022	9/32	88	43	45	40
167-1024	5/16	92	44	48	44
167-1026	11/32	97	44	50	45
167-1028	3/8	110	45	85	80
167-1030	7/16	119	48	110	100
167-1032	½	140	55	170	155
167-1034	9/16	150	58	195	180
167-1036	5/8	162	63	270	245
167-1038	11/16	168	65	355	325
167-1040	¾	178	73	450	415
167-1042	13/16	184	77	565	520
167-1044	7/8	187	79	650	595
167-1046	15/16	192	82	825	755
167-1048	1	200	85	925	840
167-1050	1-1/16	213	93	1220	1115

Wrench, Hex Key With Ball
No.167A



Number	S mm	L mm	H mm	Be-Cu g	Al-Cu g
167A-2	2	50	16	3	2
167A-3	3	63	20	5	4
167A-4	4	70	25	12	11
167A-5	5	80	28	22	20
167A-6	6	90	32	30	27
167A-7	7	95	34	50	45
167A-8	8	100	36	56	51
167A-9	9	106	38	85	76
167A-10	10	112	40	100	90
167A-11	11	118	42	140	125
167A-12	12	125	45	175	160

Wrench, Hex Key

No.167B



Number	S mm	L mm	H mm	Be-Cu g	Al-Cu g
167B-2	2	50	16	3	2
167B-3	3	63	20	5	4
167B-4	4	70	25	12	11
167B-5	5	80	28	22	20
167B-6	6	90	32	30	27
167B-7	7	95	34	50	45
167B-8	8	100	36	56	50
167B-9	9	106	38	85	77
167B-10	10	112	40	100	90
167B-11	11	118	42	140	126
167B-12	12	125	45	162	145

**Wrench, T Type Hex Key
No.167C**



Number	S mm	L mm	H mm	Be-Cu g	Al-Cu g
167C-2	2	90	100	55	50
167C-3	3	90	100	55	50
167C-4	4	90	100	75	70
167C-5	5	90	100	85	75
167C-6	6	90	100	100	90
167C-8	8	90	100	100	90
167C-10	10	90	100	150	135

**Wrench, Square Key
No.167D**

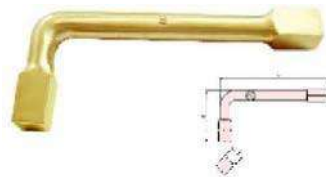

Number	S mm	L mm	H mm	Be-Cu g	Al-Cu g
167D-8	8	92	44	55	50
167D-9	9	97	44	65	60
167D-10	10	110	45	90	80
167D-11	11	119	48	110	100
167D-12	12	130	52	155	140
167D-13	13	140	54	185	170
167D-14	14	150	58	220	200
167D-15	15	156	60	280	250
167D-16	16	162	63	320	290
167D-17	17	168	65	395	355
167D-18	18	173	69	465	420
167D-19	19	177	72	520	470

**Wrench,
No.168**



Number	L mm	S mm	Be-Cu g	Al-Cu g
168-1002	450	40	1205	1102

**Wrench,
No.169**



Number	L mm	S1 mm	S2 mm	Be-Cu g	Al-Cu g
169-1002	200	14.5	18.5	370	335
169-1004	250	17.5	25.5	635	575
169-1006	450	25.5	34	2385	2160

**Wrench,
No.170**



Number	L mm	Φ mm	H mm	Be-Cu g	Al-Cu g
170-1002	600	32	32	4500	4115

Valve Spanner (U Type)
No.170A

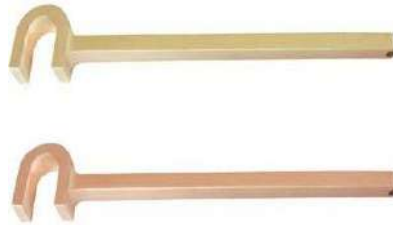

Number	L mm	Kmax mm	Be-Cu g	Al-Cu g
170A-1002	234	20	260	235
170A-1004	280	30	820	740
170A-1006	335	35	980	885
170A-1008	400	35	1640	1480

Valve Spanner (U Type)
No.170B



Number	L mm	Kmax mm	Be-Cu g	Al-Cu g
170B-1002	226	20	370	335

Oxygen Bottle Wrench
No.171

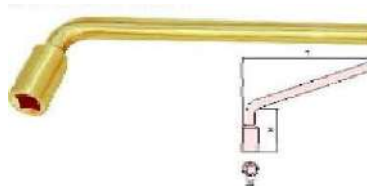

Number	C inch	L mm	H mm	Be-Cu g	Al-Cu g
171-1002	3/8	154	58	185	170

Wrench, T – Type Sliding Hex

No.172

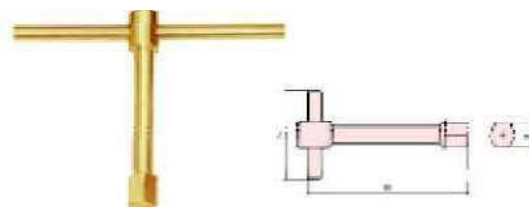

Number	S mm	L mm	H mm	Be-Cu g	Al-Cu g
172-10	10	150	110	270	245
172-12	12	170	130	290	265
172-14	14	170	140	400	365
172-17	17	190	150	465	423
172-19	19	220	160	615	563
172-22	22	240	170	660	605
172-24	24	260	180	935	855
172-27	27	260	190	1000	915
172-30	30	280	200	1306	1195
172-32	32	280	210	1505	1375
172-36	36	300	216	1802	1645
172-41	41	300	226	2075	1895

Wrench, Hook

No.173



Number	D mm	L mm	Be-Cu g	Al-Cu g
173-1002	30-32	140	63	50
173-1004	34-36	170	95	85
173-1006	40-42	176	105	95
173-1008	45-50	209	160	145
173-1010	52-55	212	170	150
173-1012	58-62	144	225	200
173-1014	68-75	250	265	240
173-1016	80-90	284	375	335
173-1018	95-100	288	415	370
173-1020	110-115	337	770	690
173-1022	120-130	343	770	690
173-1024	135-145	388	1110	1000

Wrench, Hook

No.173A



Number	D mm	mm	Be-Cu g	Al-Cu g
173A-1002	118	280	350	310

Wrench, Adjustable Hook

No.173B



Number	D mm	L mm	Be-Cu g	Al-Cu g
173B-1002	19-50	162	120	110
173B-1004	32-75	205	260	235
173B-1006	50-120	288	515	460
173B-1006	115-170	310	670	600

Hook Wrench With Pin

No.173C



Number	D mm	L mm	Be-Cu g	Al-Cu g
173C-1002	30-32	140	63	50
173C-1004	34-36	170	95	85
173C-1006	40-42	176	105	95
173C-1008	45-50	209	160	145
173C-1010	52-55	212	170	150
173C-1012	58-62	244	225	200
173C-1014	68-75	250	265	240
173C-1016	80-90	284	375	335
173C-1018	95-100	288	415	370
173C-1020	110-115	337	770	690

Valve Handle

No.174

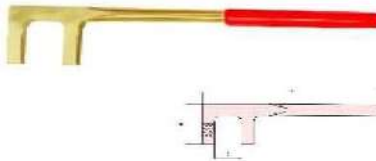

Number	S mm	L mm	H mm	Be-Cu g	Al-Cu g
174-30	30	200	44	405	340
174-35	35	250	49	465	410
174-40	40	300	50	595	540
174-45	45	350	61	835	762
174-48	48	375	62	865	790
174-50	50	400	67	892	815
174-55	55	450	73	1270	1110
174-60	60	500	79	1570	1435
174-65	65	550	80	1920	1755
174-70	70	600	80	1945	1775
174-75	75	650	85	2245	2055
174-80	80	700	91	2405	2190
174-85	85	750	97	3050	2770
174-90	90	800	103	3360	3060
174-93	93	850	107	3553	3250
174-96	96	900	110	3870	3515
174-100	100	1000	114	4170	3795
174-103	103	1200	120	6330	5765

Valve Handle

No.174A



Number	S mm	L mm	H mm	Be-Cu g	Al-Cu g
174A-30	30	200	46	265	240
174A-35	35	250	52	375	340
174A-40	40	300	54	450	400
174A-45	45	350	60	585	530
174A-50	50	400	68	740	670
174A-55	55	450	74	830	750
174A-60	60	500	80	1200	1100
174A-65	65	550	83	1280	1160
174A-70	70	600	88	1380	1250
174A-75	75	650	93.5	1650	1500
174A-80	80	700	99.5	1870	1700
174A-85	85	750	100	2090	1900
174A-90	90	800	107	2310	2100
174A-95	95	900	112	2980	2700
174A-100	100	1000	117	3330	3010

Valve Handle

No.174B



Number	S mm	L mm	H mm	Be-Cu g	Al-Cu g
174B-30	30	200	46	265	240
174B-35	35	250	52	375	340
174B-40	40	300	54	450	400
174B-45	45	350	60	585	530
174B-50	50	400	68	740	670
174B-55	55	450	74	830	750
174B-60	60	500	80	1200	1100
174B-65	65	550	83	1280	1160
174B-70	70	600	88	1380	1250
174B-75	75	650	93.5	1650	1500
174B-80	80	700	99.5	1870	1700
174B-85	85	750	100	2090	1900
174B-90	90	800	107	2310	2100
174B-95	95	900	112	2980	2700
174B-100	100	1000	117	3330	3010

Valve Handle

No.175

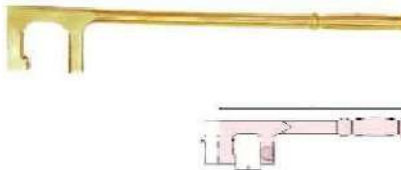

Number	S mm	L mm	H mm	Be-Cu g	Al-Cu g
175-22	22	200	50	390	345
175-28	28	250	53	550	475
175-34	34	300	56	722	615
175-39	39	350	60	905	780
175-44	44	400	64	1050	910
175-48	48	450	69	1260	1130
175-53	53	500	74	1405	1250
175-58	58	550	79	1890	1720
175-63	63	600	84	2220	2005

Valve Handle

No.176



Number	S mm	L mm	H mm	Be-Cu g	Al-Cu g
176-30	30	200	44	280	250
176-32	32	300	50	540	490
176-35	35	250	47	364	325
176-40	40	300	50	470	422
176-45	45	350	58	610	540
176-48	48	375	62	660	595
176-50	50	400	67	705	615
176-55	55	450	73	960	870
176-60	60	500	79	1205	1105
176-65	65	550	82	1370	1250
176-70	70	600	85	1540	1360
176-75	75	650	88	1705	1540
176-80	80	700	91	1910	1650
176-85	85	750	97	2250	2015
176-90	90	800	103	2380	2130

Valve Spanner

No.176A



Number	K mm	L mm	Be-Cu g	Al-Cu g
176A-1002	40	355	915	825

Valve Spanner

No.176B

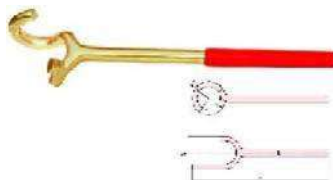

Number	B mm	Φ mm	L mm	Be-Cu g	Al-Cu g
176B-1002	60	36	370	730	650
176B-1004	80	48	430	1520	1350
176B-1006	102	62	550	2250	2000

Valve Spanner

No.176C

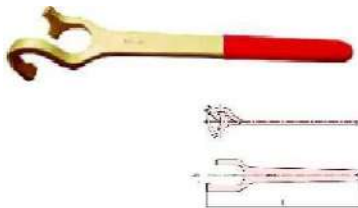

Number	B mm	R mm	L mm	Be-Cu g	Al-Cu g
176C-1002	30	15	250	415	375
176C-1004	40	20	300	540	485
176C-1006	50	25	400	1050	950
176C-1008	60	30	550	1800	1630
176C-1010	130	65	750	4900	4430

Valve Spanner

No.176D



Number	B mm	R mm	L mm	Be-Cu g	Al-Cu g
176D-1002	50	22.5	290	775	700
176D-1004	60	35.5	430	1770	1580
176D-1006	80	40	520	2770	2500
176D-1008	90	45	660	4080	3660

Valve Spanner

No.176E



Number	S mm	H mm	L mm	Be-Cu g	Al-Cu g
176E-1002	40	50	300	590	540
176E-1004	55	74	450	1165	1050
176E-1006	70	80	600	1950	1700
176E-1008	90	100	800	2800	2600

Valve Spanner

No.176F



Number	L mm	A mm	Be-Cu g	Al-Cu g
176F-200	200	25	220	200
176F-250	250	35	375	340
176F-300	300	42	440	400
176F-350	350	62	660	600
176F-400	400	90	1030	940
176F-450	450	110	1430	1300
176F-500	500	165	2090	1900
176F-550	550	225	2420	2200

Wrench, Bung
No.177



Number	L mm	H mm	Be-Cu g	Al-Cu g
177-1002	300	70	630	580

Wrench, Bung
No.178



Number	L mm	H1 mm	H2 mm	Al-Cu g	Al-Cu g
178-1002	350	70	95	1165	1070

DAMAN INTERNATIONAL INDIA
NON SPARKING TOOLS
Tel: 91-11-40521948 / 8076477394
E-Mail: akm4351@yahoo.co.in

Wrench, Bung
No.179

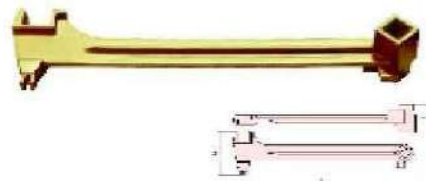

Number	L mm	H1 mm	H2 mm	Al-Cu g	Al-Cu g
179-1002	385	93	61	1250	1150

Wrench, Bung
No.179A



Number	L mm	S1 mm	S2 mm	Al-Cu g	Al-Cu g
179A-1002	300	38	52	830	750

Wrench, Bung
No.179B



Number	L mm	C mm	K1 Mm	K2 mm	Be-Cu g	Al-Cu g
179B-1002	520	19	40	73	1120	1100

Drum Opener

No.179C



Number	Number	Be-Cu	Al-Cu
179A-1002	NS-200	3100	2800

Ratchet Wrench

No.180



Number	S mm	L mm	H mm	Be-Cu g	Al-Cu g
180-22	22	270	50	580	520
180-24	24	280	53	620	560
180-27	27	290	56	730	660
180-30	30	300	58	800	720
180-32	32	310	60	900	810
180-36	36	320	65	1000	900
180-38	38	320	65	1150	1030
180-41	41	330	70	1500	1350

DAMAN INTERNATIONAL INDIA
NON SPARKING TOOLS
Tel: 91-11-40521948 / 8076477394
E-Mail: akm4351@yahoo.co.in

Ratchet Wrench
No.180A

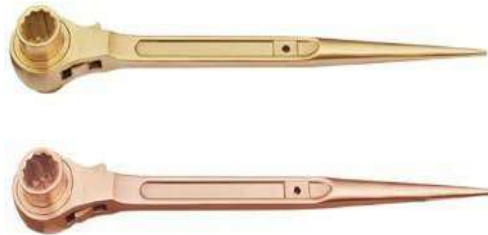

Number	S1 mm	S2 mm	L mm	Be-Cu g	Al-Cu g
180A-1417	14	17	280	410	370
180A-1719	17	19	310	450	410
180A-1922	19	22	345	530	480
180A-2224	22	24	365	680	620
180A-2427	24	27	380	860	780
180A-2730	27	30	400	990	900
180A-3032	30	32	400	1025	930
180A-3236	32	36	450	1450	1300
180A-3641	36	41	495	1860	1690

Ratchet Wrench
No.180B



Number	S mm	L mm	Be-Cu g	Al-Cu g
180B-22	22	400-650	1700	1550
180B-24	24	450-700	2000	1820
180B-27	27	500-750	2500	2280
180B-30	30	535-800	3000	2730
180B-32	32	535-800	3150	2870
180B-36	36	580-880	3350	3000
180B-41	41	600-900	3600	3280

Ratchet Wrench

No.181



Number	S mm	L mm	H mm	Be-Cu g	Al-Cu g
181-17	17	290	35	720	650
181-19	19	300	35	850	750
181-22	22	320	38	995	890
181-24	24	329	39	1230	1100
181-27	27	380	39	1500	1350
181-30	30	433	42	1900	1600
181-32	32	435	42	1935	1700
181-36	36	487	43	2580	2320

Ratchet Wrench

No.182



Number	S mm	L mm	H mm	Be-Cu g	Al-Cu g
182-17	17	230	35	725	621
182-19	19	240	35	745	652
182-21	21	250	38	942	831
182-22	22	260	38	963	835
182-24	24	270	39	1175	1022
182-26	26	280	39	1221	1053
182-27	27	285	39	1253	1102
182-30	30	300	42	1532	1325
182-32	32	315	42	1622	1427
182-35	35	325	43	1821	1633
182-36	36	330	43	1829	1673
182-41	41	330	45	2129	1948

DAMAN INTERNATIONAL INDIA

NON SPARKING TOOLS

Tel: 91-11-40521948 / 8076477394

E-Mail: akm4351@yahoo.co.in

Ratchet Wrench

No.183

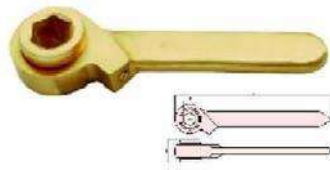

Number	S mm	L mm	H mm	Be-Cu g	Al-Cu g
183-17	17	250	35	710	650
183-19	19	250	42	896	820
183-21	21	250	42	1030	940
183-22	22	250	42	1105	1010
183-24	24	250	48	1345	1230
183-26	26	250	48	1365	1250
183-27	27	250	48	1580	1450
183-30	30	250	53	1795	1640
183-32	32	250	53	1990	1820
183-35	35	250	60	2010	1840
183-36	36	250	60	2225	2035

Ratchet Wrench

No.183A



Number	S mm	L mm	Be-Cu g	Al-Cu g
183A-9	9	150	125	110
183A-11	11	150	125	110
183A-13	13	155	160	140
183A-14	14	155	160	140
183A-17	17	200	260	230
183A-19	19	200	260	230
183A-22	22	220	340	300
183A-24	24	220	340	300
183A-27	27	245	560	500
183A-30	30	280	840	750
183A-32	32	280	840	750
183A-36	36	290	1180	1050
183A-41	41	295	1230	1100
183A-46	46	360	2060	1850
183A-50	50	360	2230	2000
183A-55	55	440	2900	2600
183A-60	60	440	2900	2600

Hammer, Bricklayers

No.184



Number	H g	L mm	g
184-1002	600	305	750
184-1004	800	340	1000

Hammer, Claw

No.185



Number	H g	L mm	g
185-1002	230	280	405
185-1004	450	300	652
185-1006	680	330	953
185-1008	910	390	1205

Carpenter's Hammer

No.185A



Number	H g	L mm	Be-Cu g	Al-Cu g
185A-9	500	300	700	700
185A-11	600	330	870	870

Hammer, Cross pein Engineers
No.186



Number	H g	L mm	G
186-1002	500	310	655
186-1004	1000	340	1175
186-1006	1500	400	1850
186-1008	2000	450	2455
186-1010	3000	700	3700
186-1012	5000	900	6000

Hammer, Ball Pein
No.187



Number	H g	L mm	G
187-1002	230	280	403
187-1004	340	280	502
187-1006	450	310	680
187-1008	680	340	950
187-1010	910	350	1205
187-1012	1130	400	1470

Hammer, Cutoff
No.188



Number	H g	L mm	g
187-1002	300	280	420
187-1004	450	310	650
187-1006	600	340	900

Hammer, Pein

No.189



Number	H g	L mm	G
189-1002	250	330	461
189-1004	300	330	570

Hammer, Cutoff (Japan Type)

No.189A



Number	H g	L mm	g
189A-1002	230	280	420
189A-1004	380	450	500

Hammer, Engineer's Cross Pein

No.189B

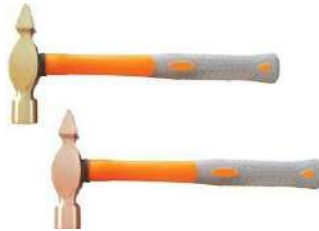

Number	H g	L mm	g
189B-1002	500	310	650
189B-1004	900	350	1100

Hammer, Scaling

No.190



Number	H g	L mm	g
190-1002	150	280	205
190-1004	300	280	370

Hammer, Sledge
No.191



Number	H g	L mm	G
191-1002	450	310	610
191-1004	1000	400	1300
191-1006	1400	400	1700
191-1008	1500	400	1800
191-1010	1800	400	2100
191-1012	2000	400	2300
191-1014	2200	400	2500
191-1016	2500	700	3210
191-1018	2700	700	3410
191-1020	3000	700	3710
191-1022	3600	700	4310
191-1024	4000	900	4910
191-1026	4500	900	5410
191-1028	5000	900	5910
191-1030	5400	900	6310
191-1032	6400	900	7310
191-1034	7200	900	8110
191-1036	8000	900	8910
191-1038	8200	900	9110
191-1040	9100	900	10010
191-1042	9900	900	10810

DAMAN INTERNATIONAL INDIA
NON SPARKING TOOLS
Tel: 91-11-40521948 / 8076477394
E-Mail: akm4351@yahoo.co.in

Hammer, Sledge

No.191A



Number	Size g	L mm	G
191A-1002	450	310	450
191A-1004	1000	400	1000
191A-1006	1400	400	1400
191A-1008	1500	400	1500
191A-1010	1800	400	1800
191A-1012	2000	400	2000
191A-1014	2200	400	2200
191A-1016	2500	700	2500
191A-1018	2700	700	2700
191A-1020	3000	700	3000
191A-1022	3600	700	3600
191A-1024	4000	900	4000
191A-1026	4500	900	4500
191A-1028	5000	900	5000
191A-1030	5400	900	5400
191A-1032	6400	900	6400
191A-1034	7200	900	7200
191A-1036	8000	900	8000
191A-1038	8200	900	8200
191A-1040	9100	900	9100
191A-1042	9900	900	9900

Hammer, Sledge

No.191B



Number	Size g	L mm	G
191B-1002	450	310	450
191B-1004	1000	400	1000
191B-1006	1400	400	1400
191B-1008	1500	400	1500
191B-1010	1800	400	1800
191B-1012	2000	400	2000
191B-1014	2200	400	2200
191B-1016	2500	900	2500
191B-1018	2700	900	2700
191B-1020	3000	900	3000
191B-1022	3600	900	3600
191B-1024	4000	900	4000
191B-1026	4500	900	4500
191B-1028	5000	900	5000
191B-1030	5400	900	5400
191B-1032	6400	900	6400
191B-1034	7200	900	7200
191B-1036	8000	900	8000
191B-1038	8200	900	8200
191B-1040	9100	900	9100
191B-1042	9900	900	9900

Hammer, Sledge (German Type)

No.191C



Number	H g	L mm	g
191C-1002	500	350	650
191C-1004	1000	400	1300
191C-1006	1500	400	1800
191C-1008	2000	400	2300
191C-1010	3000	700	3700
191C-1012	4000	900	4900
191C-1014	5000	900	5900

Club Hammer

No.191D



Number	Size lb	G
191D-1002	2	910
191D-1004	4	1800

Nylon Hammer

No.191E



Number	Size g	L mm	G
191E-1002	800	340	800
191E-1004	1000	400	1000

Nylon Hammer

No.191F



Number	Size g	L mm	G
191F-1002	420	280	420
191F-1004	650	340	650

Sledge Hammer
No.191G



Number	Size g	L mm	G
191G-1002	450	310	640
191G-1004	1000	320	1200
191G-1006	1400	360	1620
191G-1008	1500	360	1720
191G-1010	1800	380	2020
191G-1012	2000	380	2240
191G-1014	2200	400	2440
191G-1016	2500	400	2740
191G-1018	2700	400	2940
191G-1020	3000	700	3630
191G-1022	3600	700	4230
191G-1024	4000	800	4790
191G-1026	4500	800	5290
191G-1028	5000	800	5790
191G-1030	5400	800	6190
191G-1032	6400	800	7190
191G-1034	7200	900	8130
191G-1036	8000	900	8930
191G-1038	8200	900	9130
191G-1040	9100	900	10030
191B-1042	9900	900	10830

DAMAN INTERNATIONAL INDIA
NON SPARKING TOOLS

Tel: 91-11-40521948 / 8076477394

E-Mail: akm4351@yahoo.co.in

Sledge Hammer

No.191H



Number	Size g	L mm	g
191H-1002	450	310	450
191H-1004	1000	360	1000
191H-1006	1400	360	1400
191H-1008	1500	360	1500
191H-1010	1800	380	1800
191H-1012	2000	380	2000
191H-1014	2200	400	2200
191H-1016	2500	400	2500
191H-1018	2700	400	2700
191H-1020	3000	700	3000
191H-1022	3600	700	3600
191H-1024	4000	800	4000
191H-1026	4500	800	4500
191H-1028	5000	800	5000
191H-1030	5400	800	5400
191H-1032	6400	800	6400
191H-1034	7200	900	7200
191H-1036	8000	900	8000
191H-1038	8200	900	8200
191H-1040	9100	900	9100
191H-1042	9900	900	9900

Hammer, Testing

No.192



Number	H g	L mm	g
192-1002	150	300	206
192-1004	250	335	345

Sledge Hammer

No.192A



Number	Size g	L mm	G
191H-1002	1000	370	1300
191H-1004	1400	370	1700
191H-1006	1500	370	1800
191H-1008	1800	370	2100
191H-1010	2000	370	2300
191H-1012	2200	370	2500
191H-1014	2500	900	3460
191H-1016	2700	900	3660
191H-1018	3000	900	3960
191H-1020	3600	900	4560
191H-1022	4000	900	4960
191H-1024	4500	900	5460
191H-1026	5000	900	5960
191H-1028	5400	900	6360
191H-1030	6400	900	7360
191H-1032	7200	900	8160
191H-1034	8000	900	8960
191H-1036	8200	900	9160
191H-1038	9100	900	10060
191H-1040	9900	900	10860

Hammer, Sledge (German Type)

No.192B



Number	H g	L mm	G
192B-1004	1000	370	1300
192B-1006	1500	370	1800
192B-1008	2000	370	2300
192B-1010	3000	900	3950
192B-1012	4000	900	4950
192B-1014	5000	900	5950

Hammer, Plumb

No.193



Number	H mm	Φ mm	Be-Cu g	Al-Cu g
193-1002	59	50	275	247

Pick Railroad

No.194



Number	Size	A mm	L mm	Be-Cu g	Al-Cu g
194-1002	1#	360	910	2100	2000
194-1004	2#	385	910	2950	2800
194-1006	3#	410	910	3385	3200
194-1008	4#	470	910	3715	3500

Pick Railroad

No.194A



Number	Size	L mm	Be-Cu g	Al-Cu g
194A-1002	1#	910	2100	2000
194A-1004	2#	910	2950	2800
194A-1006	3#	910	3385	3200
194A-1008	4#	910	3715	3500

Axe Fineman

No.195



Number	L mm	H mm	B mm	Be-Cu g	Al-Cu g
195-1002	340	200	98	1425	1300

Axe

No.196



Number	L mm	H mm	B mm	Be-Cu g	Al-Cu g
196-1002	340	145	82	980	890

Anvil Block

No.197



Number	Size g	H mm	K mm
197-1002	3000	63	92
197-1004	5000	75	111
197-1006	16000	114	160

Shovel, Square

No.198



Number	L mm	B mm	H mm	Be-Cu g	Al-Cu g
198-1002	940	175	340	1410	1290
198-1004	990	240	418	1804	1650

Shovel, Square
No.198A

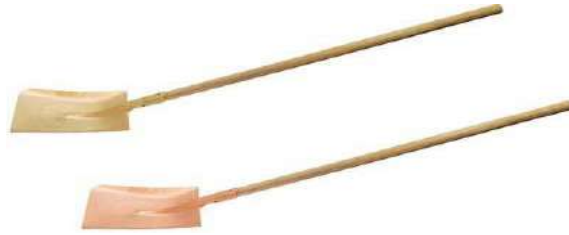

Number	L mm	B mm	H mm	Be-Cu g	Al-Cu g
198A-1002	1400	175	340	1800	1680
198A-1004	1450	240	418	2200	2050

Dust Pan
No.199



Number	L mm	B mm	H mm	Be-Cu g	Al-Cu g
199-1002	990	270	520	2330	2130

Shovel, Round Point
No.200



Number	L mm	B mm	H mm	Be-Cu g	Al-Cu g
200-1002	990	240	420	1553	1420

Shovel, Round Point

No.200A



Number	L mm	B mm	H mm	Be-Cu g	Al-Cu g
200-1002	830	170	300	1300	1220

Shovel, Round Point

No.200B



Number	L mm	B mm	H mm	Be-Cu g	Al-Cu g
200B-1002	1450	240	420	1553	1420

Folding Spade

No.201



Number	L mm	B mm	H mm	Be-Cu g	Al-Cu g
201-1002	320	180	130	1500	1350

Edging Spade
No.201A

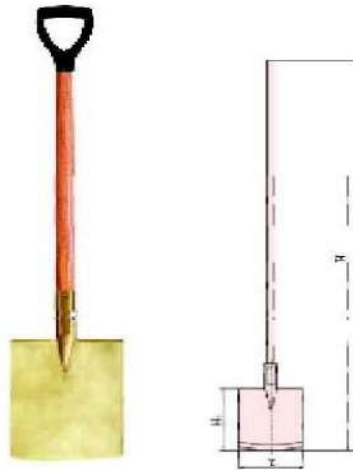

Number	H mm	B mm	H1 mm	Be-Cu g	Al-Cu g
201A-1002	1390	195	290	3500	3200
201A-1004	1440	175	340	3700	3480

Knife, Common
No.202



Number	L mm	L1 mm	Be-Cu g	Al-Cu g
202-1002	80	185	75	105
202-1004	145	250	95	125

Knife
No.202A



Number	L mm	L1 mm	Be-Cu g	Al-Cu g
202A-1002	95	203	80	110

Knife , Common

No.202B



Number	L mm	L1 mm	Be-Cu g	Al-Cu g
202B-1002	80	193	75	105
202B-1004	137	250	95	125

Knife, Putty

No.203



Number	K mm	L mm	L1 mm	Be-Cu g	Al-Cu g
203-1002	25	95	200	75	90
203-1004	40	95	200	95	115
203-1006	50	95	200	105	120
203-1008	65	95	200	115	125

Knife, Putty

No.203A



Number	K mm	L mm	L1 mm	Be-Cu g	Al-Cu g
203A-1002	25	90	203	75	90
203A-1004	40	90	203	95	115
203A-1006	50	90	203	105	120
203A-1008	65	90	203	115	125

Knife, Putty
No.203B



Number	K mm	L mm	L1 mm	Be-Cu g	Al-Cu g
203B-1002	75	90	203	150	165
203B-1004	100	90	203	175	195
203B-1006	150	140	253	280	310

Knife, Putty
No.204



Number	K mm	L mm	L1 mm	Be-Cu g	Al-Cu g
204-1002	75	95	200	100	165
204-1004	100	95	200	105	195
204-1006	150	145	250	215	310

Spatula
No.204A

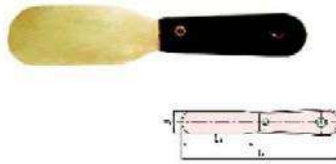

Number	B mm	L mm	L1 mm	Be-Cu g	Al-Cu g
204A-1002	30	203	90	85	80
204A-1004	50	218	105	115	110
204A-1006	90	233	120	160	145

Electrician Knife

No.204B

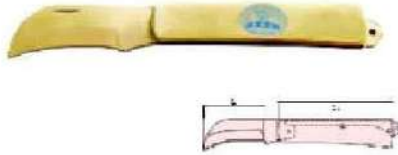

Number	L mm	L1 mm	Be-Cu g	Al-Cu g
204B-1002	61	113	210	185

Knife, Putty

No.204C



Number	K mm	L mm	L1 mm	Be-Cu g	Al-Cu g
204A-1002	25	95	200	75	90
204A-1004	40	95	200	95	115
204A-1006	50	95	200	105	120
204A-1008	65	95	200	115	125

Spatula

No.204D

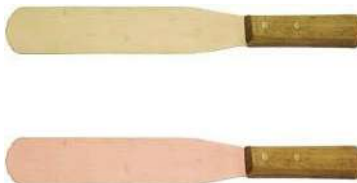

Number	K mm	L mm	L1 mm	Be-Cu g	Al-Cu g
204D-1002	40	350	230	120	110

Knife, Putty
No.204E



Number	K mm	L mm	L1 mm	Be-Cu g	Al-Cu g
204E-1002	75	95	200	100	165
204E-1004	100	95	200	105	195
204E-1006	150	145	250	215	310

Knife
No.204F



Number	L mm	L1 mm	Be-Cu g	Al-Cu g
204E-1002	110	216	90	120

Knife
No.204G



Number	L mm	L1 mm	Be-Cu g	Al-Cu g
204F-1002	75	180	90	120

**Scraper
No.205**

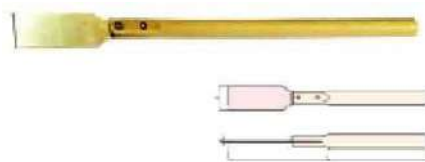

Number	L mm	B mm	H mm	Be-Cu g	Al-Cu g
205-1002	902	50	2	683	625

**Scraper
No.205A**



Number	L mm	B mm	H mm	Be-Cu g	Al-Cu g
205A-1002	902	50	2	683	625

**Scraper, Flat
No.206**

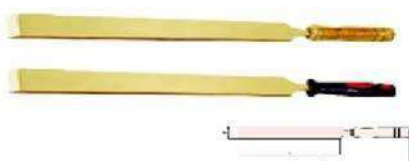

Number	L mm	B mm	L1 mm	Be-Cu g	Al-Cu g
206-1002	200	30	325	330	300
206-1004	300	30	430	480	440
206-1006	350	35	490	640	580
206-1008	350	50	500	1020	910
206-1010	400	60	560	1520	1330

Scraper, Deck
No.207

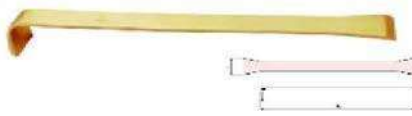

Number	L mm	B mm	Be-Cu g	Al-Cu g
207-1002	250	39	285	255
207-1004	300	45	380	335
207-1006	350	55	555	507
207-1008	400	50	775	700
207-1010	650	56	1405	1290
207-1012	750	58	1540	1380

Number	L inch	B inch	Be-Cu g	Al-Cu g
207A-1002	12	2	460	425

Scraper, Deck
No.208

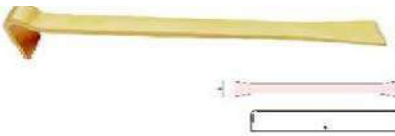

Number	L mm	B mm	Be-Cu g	Al-Cu g
208-1002	270	40	371	338

Scraper, Deck
No.209

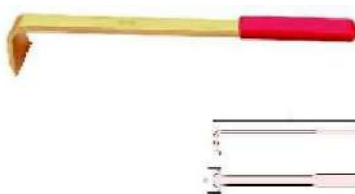

Number	L mm	B mm	Be-Cu g	Al-Cu g
209-1002	300	48	432	391

Scraper, Deck
No.210

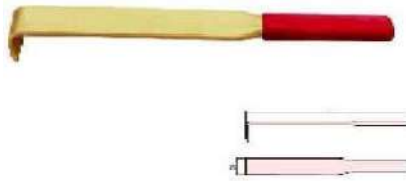

Number	L mm	B mm	Be-Cu g	Al-Cu g
210-1002	380	38	821	720

Scraper, Spray Booth
No.211



Number	L mm	B mm	Be-Cu g	Al-Cu g
211-1002	235	76	392	358

Scraper,
No.212



Number	L mm	L1 mm	B mm	Be-Cu g	Al-Cu g
212-1002	690	90	50	550	520
212-1004	705	100	75	750	700
212-1006	720	115	100	850	800
212-1008	765	150	150	1400	1300

Scraper, Hand Style

No.212A



Number	L mm	L1 mm	B mm	Be-Cu g	Al-Cu g
212A-1002	480	95	95	600	540

Scraper, Rust

No.212B



Number	L mm	B mm	L1 mm	Be-Cu g	Al-Cu g
212B-1002	600	75	75	700	620

Scraper, Arched

No.213



Number	L mm	L1 mm	B mm	Be-Cu g	Al-Cu g
213-1002	600	120	50	650	600
213-1004	710	120	100	925	830
213-1006	720	120	150	1080	980

Scraper, Floor

No.213A

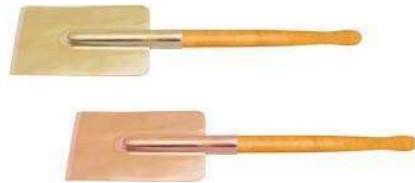

Number	L mm	L1 mm	B mm	Be-Cu g	Al-Cu g
213B-1002	460	170	150	1150	1000

Opener Carbide Drum

No.214

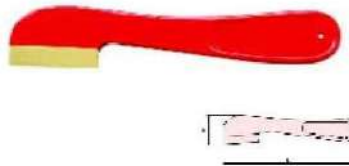

Number	L mm	B mm	Be-Cu g	Al-Cu g
214-1002	280	53	655	595

Scraper, Tile Cleaver

No.215



Number	L mm	L1 mm	B mm	Be-Cu g	Al-Cu g
215-1002	180	350	55	610	550

**DAMAN INTERNATIONAL INDIA
NON SPARKING TOOLS**

Tel: 91-11-40521948 /8076477394

E-Mail: akm4351@yahoo.co.in

Trowel Bricklayers

No.215A



Number	L mm	L1 mm	B mm	Be-Cu g	Al-Cu g
215A-1002	335	215	130	700	620

Trapezia Shovel Bricklayers

No.215B



Number	L mm	L1 mm	B mm	Be-Cu g	Al-Cu g
215B-1002	290	160	80	420	390

Plane 's Blade

No.216



Number	L mm	B mm	Be-Cu g
216-1002	175	43	130

File, Flat
No.217



Number	L inch	L mm	B mm	H mm	Be-Cu g
217-1002	6	150	16	4	75
217-1004	8	200	21	4.5	160
217-1006	10	250	25	6	282
217-1008	12	300	30	6.5	455
217-1010	14	350	32	8	675
217-1012	16	400	32	9.5	925

File, Half Round
No.218



Number	L inch	L mm	B mm	H mm	Be-Cu g
218-1002	6	150	22	6	105
218-1004	8	200	23	7	190
218-1006	10	250	26	8	255
218-1008	12	300	28	9	375
218-1010	14	350	30	10	565

File Round
No.219



Number	L inch	L mm	Φ mm	Be-Cu g
219-1002	6	150	6.5	45
219-1004	8	200	7.5	91
219-1006	10	250	8.5	122
219-1008	12	300	9.5	180
219-1010	14	350	10.5	250

File, Square

No.220



Number	L inch	L mm	B mm	Be-Cu g
220-1002	8	200	8	130
220-1004	10	250	10	155
220-1006	12	300	11	202
220-1008	14	350	12	303

File, Triangle

No.221



Number	L inch	L mm	B mm	Be-Cu g
221-1002	8	200	12	115
221-1004	10	250	13	125
221-1006	12	300	14	160
221-1008	14	350	14	205

Punch, Machinists

No.222

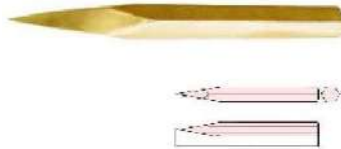

Number	S mm	L mm	Be-Cu g	Al-Cu g
222-1002	14	150	165	155
222-1004	18	200	385	355
222-1006	20	250	610	555
222-1008	20	300	725	660

Chisel, Penumatic Bull Point

No.223

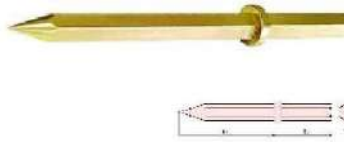

Number	S mm	L mm	L1 mm	Be-Cu g	Al-Cu g
223-1002	28	500	150	2650	2400

Punch, Machinists

No.223A



Number	Φ mm	L mm	Be-Cu g	Al-Cu g
223A-1002	5	150	235	215
223A-1004	8	150	285	255
223A-1006	10	150	345	315

Drift Cylindrical

No.223B



Number	Φ mm	Φ1 mm	L mm	Be-Cu g	Al-Cu g
223B-1002	3	9	110	20	15
223B-1004	4	10	110	57	50
223B-1006	6	12	115	105	95
223B-1008	8	14	120	130	115
223B-1010	10	16	145	200	180
223B-1012	12	18	160	280	260
223B-1014	14	20	180	410	380
223B-1016	16	24	200	640	600
223B-1018	18	30	225	1070	960
223B-1020	20	32	225	1230	1110

Punch
No.223C

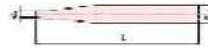

Number	Φ mm	$\Phi 1$ mm	L mm	Be-Cu g	Al-Cu g
223C-1002	5	11	150	105	95
223C-1004	6	12	150	130	115
223C-1006	7	13	150	150	135
223C-1008	8	14	150	170	150
223C-1010	10	16	175	255	230
223C-1012	12	18	175	335	300
223C-1014	13	29	255	1180	1060

Punch, Machinists
No.223D



Number	L mm	Φ mm	Be-Cu g	Al-Cu g
223D-1002	160	18	290	265
223D-1004	250	18	470	425
223D-1006	300	18	600	545
223D-1008	300	20	700	635
223D-1010	300	25	1100	995
223D-1012	400	18	800	725
223D-1014	400	20	1000	885

Drift Pin, Barrel Straight

No.223E



Number	L mm	Φ mm	Φ1 mm	Be-Cu g	Al-Cu g
223E-1002	150	8	11	125	118
223E-1004	150	10	13	155	140
223E-1006	150	12	15	215	190
223E-1008	200	14	18	420	380
223E-1010	200	15	19	435	390
223E-1012	200	16	20	480	435
223E-1014	200	17	21	570	540
223E-1016	250	18	22	600	560
223E-1018	250	19	23	860	780
223E-1020	250	20	24	875	790
223E-1022	250	21	25	950	885
223E-1024	250	22	26	965	920
223E-1026	250	24	28	1270	1150
223E-1028	250	25	29	1300	1170
223E-1030	250	26	30	1390	1250
223E-1032	300	27	31	1900	1770

Scraper, Triangular

No.224



Number	L mm	L1 mm	K mm	Be-Cu g	Al-Cu g
224-1002	160	300	22	245	225
224-1004	300	400	26	645	590

Scraper, Plate

No.224A



Number	L mm	B mm	Be-Cu g	Al-Cu g
224A-1002	470	150	900	810

Scraper, Halfmoon

No.224B



Number	L mm	B mm	Be-Cu g	Al-Cu g
224B-1002	326	100	260	235

Scraper, Triangular

No.224C



Number	L mm	L1 mm	K mm	Be-Cu g	Al-Cu g
224C-1002	440	300	20	420	380

Scraper, Half Round

No.224D

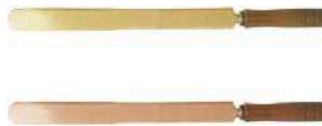

Number	L mm	L1 mm	B mm	H mm	Be-Cu g	Al-Cu g
224C-1002	440	300	30	5	420	380

Chisel, Cross

No.225



Number	S mm	L mm	H mm	Be-Cu g	Al-Cu g
225-1002	20	200	8	475	432

Chisel, Cross Cutting
No.225A

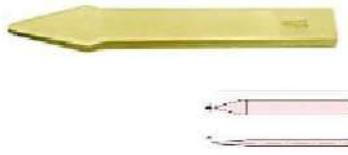

Number	L mm	B mm	H mm	Be-Cu g	Al-Cu g
225A-1002	140	4	4	280	255
225A-1004	200	4	4	480	435
225A-1006	300	5	5	840	760

Scraper Pick And Scaler
No.225B

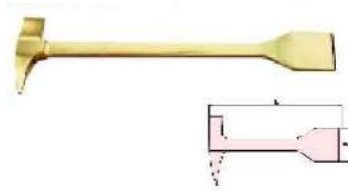

Number	L mm	B mm	Be-Cu g	Al-Cu g
225B-1002	450	75	1285	1155

Chisel, Flat
No.225C



Number	L mm	B mm	Be-Cu g	Al-Cu g
225C-1002	22	150	235	205
225C-1004	22	200	320	280
225C-1006	24	250	490	440
225C-1008	25	300	770	700
225C-1010	27	400	1220	1100

Chisel, Penumatic

No.226

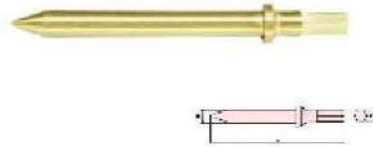

Number	S mm	L mm	Φ mm	Be-Cu g	Al-Cu g
226-1002	10	125	12	117	102
226-1004	10	175	12	168	143

Chisel, Penumatic

No.227



Number	S mm	L mm	B mm	H mm	Be-Cu g	Al-Cu g
227-1002	10	125	20	2	160	141
227-1004	10	175	20	2	210	182

Chisel, Penumatic

No.228



Number	S mm	L mm	B mm	Be-Cu g	Al-Cu g
228-1002	10	125	20	152	117
228-1004	10	175	20	190	122

Chisel, Penumatic

No.229



Number	S mm	L mm	H mm	B mm	Be-Cu g	Al-Cu g
229-1002	10	125	2	20	162	142
229-1004	10	175	2	20	213	183

Chisel, Penumatic

No.230



Number	S mm	L mm	B mm	H mm	Be-Cu g	Al-Cu g
230-1002	10	125	20	2	127	112
230-1004	10	175	20	2	178	153

Chisel, Flat

No.231



Number	L mm	Φ mm	B mm	Be-Cu g	Al-Cu g
231-1002	160	14	14	175	160
231-1004	160	16	16	231	210
231-1006	160	18	18	295	271
231-1008	200	18	18	382	342
231-1010	200	20	20	473	430
231-1012	250	24	24	822	751
231-1014	300	24	24	1025	942
231-1016	300	25	25	1302	1002
231-1018	400	25	25	1502	1360
231-1020	500	25	25	1903	1730
231-1022	500	30	30	2730	2481

Chisel Hex/6 Point

No.232



Number	S mm	L mm	B mm	Be-Cu g	Al-Cu g
232-1002	10	150	12	98	92
232-1004	14	200	16	251	231
232-1006	16	160	18	262	242
232-1008	14	250	16	320	302
232-1010	17	300	19	772	701
232-1012	17	350	19	903	821
232-1014	22	600	24	1861	1702
232-1016	25	300	28	1204	1090
232-1018	30	500	35	2860	2620

Chisel, 8 Point

No.233



Number	L mm	S mm	B mm	Be-Cu g	Al-Cu g
233-1002	160	14	14	186	170
233-1004	160	16	16	255	230
233-1006	180	19	19	402	366
233-1008	200	19	19	451	411
233-1010	200	22	22	650	562
233-1012	250	24	24	880	792
233-1014	300	24	24	1052	950
233-1016	300	30	30	1603	1450
233-1018	400	27	27	1780	1620

Chisel, Diamond Point

No.233A



Number	S mm	L mm	B mm	Be-Cu g	Al-Cu g
233A-1002	20	200	13	580	525

Caulking Tool

No.234



Number	L mm	B mm	H mm	Be-Cu g	Al-Cu g
234-1002	200	20	5	495	455
234-1004	250	20	8	652	585

Caulking Tool

No.234A

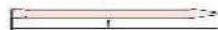

Number	S mm	L mm	Be-Cu g	Al-Cu g
234A-1002	50	1200	18450	16850

Wedge, Flange

No.235



Number	L mm	B mm	H mm	e-Cu g	Al-Cu g
235-1002	80	13	6	25	23
235-1004	100	50	10	201	185
235-1006	135	50	18	497	455
235-1008	150	40	8	200	180
235-1010	150	25	8	122	112
235-1012	150	25	13	205	185
235-1014	150	50	13	400	365
235-1016	180	32	13	305	280
235-1018	180	50	19	700	640
235-1020	200	20	30	490	451
235-1022	200	30	30	740	675
235-1024	200	40	40	315	1200
235-1026	200	50	12	500	450
235-1028	230	40	20	751	690
235-1030	250	40	30	230	1125
235-1032	300	50	40	460	2250

Number	L mm	B mm	H mm	Be-Cu g	Al-Cu g
235-1002	4	3/4	1/2	110	100
235-1003	6	1	1/2	220	200
235-1005	6	1-1/2	3/4	480	435
235-1007	7	2	3/4	755	680
235-1009	8	1-1/2	1	855	770
235-1011	8-1/2	2	1-1/4	1500	1360

Punch, Center

No.236



Number	L mm	Φ mm	Be-Cu g	Al-Cu g
236-1002	100	16	145	125
236-1004	150	16	230	205
236-1006	200	18	392	340
236-1008	300	18	615	540
236-1010	400	18	820	740
236-1012	500	20	1230	1102
236-1014	500	30	2740	2480

Bar

No.237



Number	L mm	Φ mm	B mm	Be-Cu g	Al-Cu g
237-1002	500	15	15	738	675
237-1004	500	19	19	1150	1050
237-1006	500	20	20	1295	1185
237-1008	500	25	25	1975	1805
237-1010	500	30	30	2925	2675
237-1012	600	25	25	2380	2175
237-1014	600	30	30	3450	3155
237-1016	800	23	23	2290	2095
237-1018	800	25	25	3175	2905
237-1020	800	30	30	4490	4105
237-1022	850	30	30	4870	4455
237-1024	1000	25	25	3985	3645
237-1026	1000	28	28	4710	4305
237-1028	1000	30	30	5595	5115
237-1030	1200	25	25	4795	4385
237-1032	1200	30	30	6970	6375
237-1034	1500	30	30	8665	7925

Bar, Pinch
No.237A

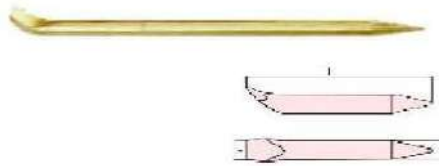

Number	L mm	Φ mm	B mm	Be-Cu g	Al-Cu g
237A-1002	500	15	16	672	615
237A-1004	500	19	20	1093	1001
237A-1006	500	20	20	1148	1052
237A-1008	500	23	23	1481	1355
237A-1010	600	25	25	2132	1950
237A-1012	800	23	23	2530	2293
237A-1014	1000	30	28	5193	4752

Bar (Hex) Pinch
No.237B

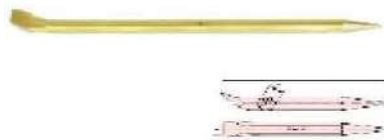

Number	L mm	S mm	B mm	Be-Cu g	Al-Cu g
237B-1002	500	18	20	1200	1090
237B-1004	500	20	22	1450	1320
237B-1006	600	20	22	1750	1600
237B-1008	1000	22	24	3500	3200
237B-1010	1000	25	27	4500	4080
237B-1012	1500	25	27	6750	6120
237B-1014	1000	35	37	8800	8000

Bar Crow
No.237C



Number	L mm	H mm	B mm	Be-Cu g	Al-Cu g
237C-1002	650	20	23	1855	1675
237C-1004	1500	30	25	8910	8110

Number	L inch	H inch	B inch	Be-Cu g	Al-Cu g
237C-1002	60	1-1/4	1-3/8	8920	8050

Bar, Pinch
No.237D



Number	L mm	H mm	B mm	Be-Cu g	Al-Cu g
237D-1002	600	3	52	2435	2221

Spile
No.237E



Number	L mm	B mm	Be-Cu g	Al-Cu g
237E-1002	600	22	2320	2100

Hearing Needle

No.238

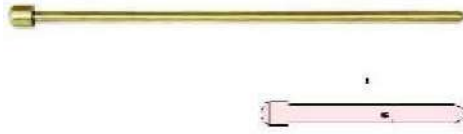

Number	L mm	Φ mm	Be-Cu g	Al-Cu g
238-1002	250	6	85	75
238-1004	300	8	150	135
238-1006	400	7	160	145
238-1008	500	10	335	305

Hearing Needle With Ball

No.238A

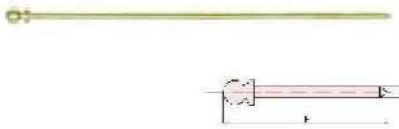

Number	L mm	Φ mm	Be-Cu g	Al-Cu g
238A-1002	500	6	130	115

Needle

No.238B

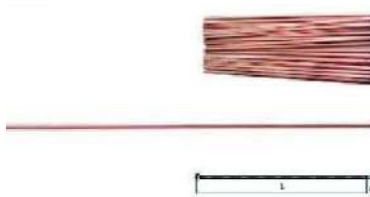

Number	L mm	Φ mm	Be-Cu g
238B-1002	180	3	12

Bar, Wrecking
No.239

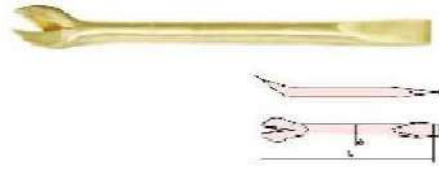

Number	L mm	Φ mm	B mm	H mm	Be-Cu g	Al-Cu g
239-1002	250	13	15	1.5	280	250

Bar, Wrecking
No.240



Number	L mm	Φ mm	Be-Cu g	Al-Cu g
240-1002	400	16	752	685
240-1004	600	16	1102	1002
240-1006	800	19	2200	2011
240-1008	1200	20	3570	3266

Bar, Wrecking Hex
No.240A

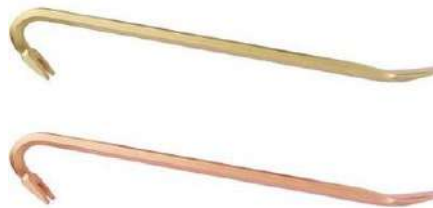

Number	L mm	S mm	Be-Cu g	Al-Cu g
240A-1002	460	16	890	800
240A-1004	760	22	3100	2800
240A-1006	920	22	3650	3300

Crate Opener

No.241



Number	L mm	H mm	Be-Cu g	Al-Cu g
241-1002	230	70	471	430

Shears, Cutting

No.242



Number	L mm	B mm	Be-Cu g	Al-Cu g
242-1002	150	61	110	100

Shears, Cutting

No.243



Number	L mm	B mm	Be-Cu g	Al-Cu g
243-1002	290	91	235	215
243-1004	360	107	900	823

Shears, Tin

No.244

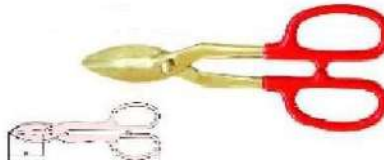

Number	L mm	B mm	Be-Cu g	Al-Cu g
244-1002	300	75	488	410

Scissors

No.244A



Number	L inch	L mm	B mm	Be-Cu g	Al-Cu g
244A-1002	9	225	98	245	210

Tinner's Snip Plate Shear

No.244B



Number	L mm	Be-Cu g	Al-Cu g
--------	---------	------------	------------

244B-1002	280	500	450
------------------	-----	-----	-----

Shears
No.244C



Number	L mm	Be-Cu g	Al-Cu g
244C-1002	200	488	410

Pliers, Adjustable Combination
No.245

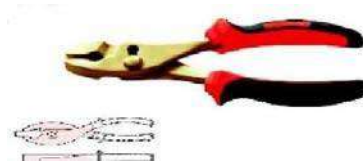

Number	L inch	L mm	K mm	Be-Cu g	Al-Cu g
245-1002	6	150	8	213	195
245-1004	8	200	13	380	350

Gas Pliers
No.245A

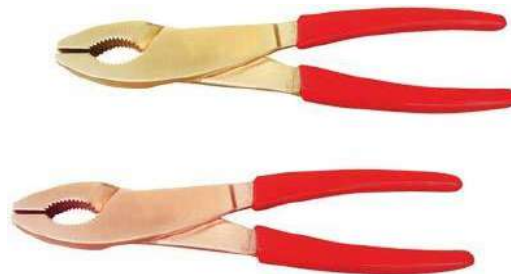

Number	L mm	Be-Cu g	Al-Cu g
245A-1002	200	350	315

Pliers, Lineman

No.246

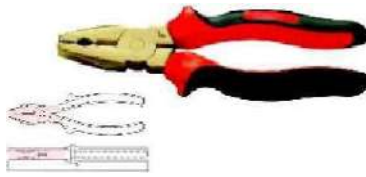

Number	L inch	L mm	Be-Cu g	Al-Cu g
246-1002	6	150	180	165
246-1004	7	175	355	330
246-1006	8	200	465	435
246-1008	10	250	550	500

Pliers, Cutting

No.247

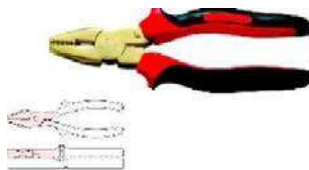

Number	L inch	L mm	Be-Cu g	Al-Cu g
247-1002	8	200	470	420

Pliers, Diagonal Cutting

No.248

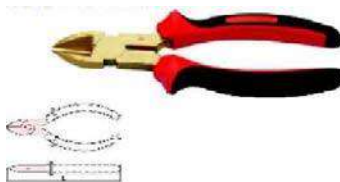

Number	L inch	L mm	Be-Cu g	Al-Cu g
248-1002	6	150	245	225
248-1004	8	200	410	365

Pincers
No.249

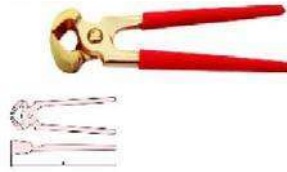

Number	L inch	L mm	Be-Cu g	Al-Cu g
249-1002	8	200	325	300

Pincers
No.249A

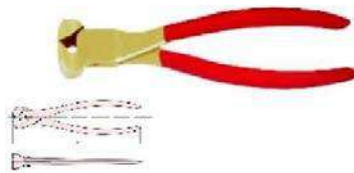

Number	L inch	L mm	Be-Cu g	Al-Cu g
249A-1002	7	175	250	225

Pliers, Flat Nose
No.250



Number	L inch	L mm	Be-Cu g	Al-Cu g
250-1002	6	150	165	151
250-1004	8	200	281	257

Pliers, Groove Joint

No.251

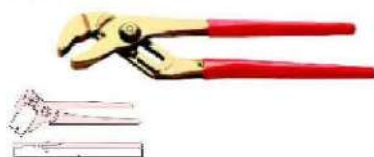

Number	L inch	L mm	K max mm	Be-Cu g	Al-Cu g
251-1002	6	150	25	150	160
251-1004	10	250	45	425	370
251-1006	12	300	55	670	600
251-1008	14	350	55	850	770

Pliers, Slip Joint

No.252



Number	L inch	L mm	K max mm	Be-Cu g	Al-Cu g
252-1002	10	250	32	365	335

Pliers, Water Pump

No.252A



Number	L inch	L mm	K max mm	Be-Cu g	Al-Cu g
252A-1002	10	250	32	325	310
252A-1004	12	300	52	665	610

Pliers, Snipe Nose

No.253

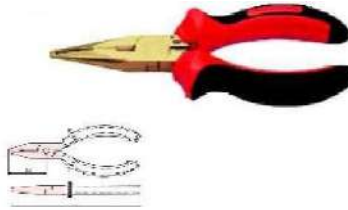

Number	L inch	L mm	L1 mm	Be-Cu g	Al-Cu g
253-1002	6	150	54	190	170
253-1004	8	200	74	335	300

Pliers, Long Nose

No.254

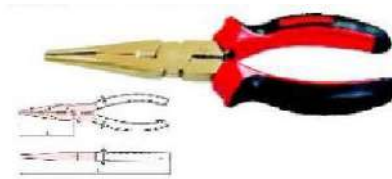

Number	L inch	L mm	L1 mm	Be-Cu g	Al-Cu g
254-1002	6	150	54	190	170
254-1004	8	200	74	335	300

Pliers, Round Nose

No.255



Number	L inch	L mm	Be-Cu g	Al-Cu g
255-1002	6	150	165	150

Pliers, Round 45 Degree Bent
No.255A



Number	L inch	L mm	Be-Cu g	Al-Cu g
255-1002	6	150	190	170

Pliers, Snap Ring – Internal
No.256

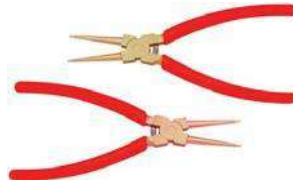

Number	L inch	L mm	Be-Cu g	Al-Cu g
256-1002	8	200	280	256
256-1004	10	250	415	380

Pliers, Snap Ring – Internal
No.257

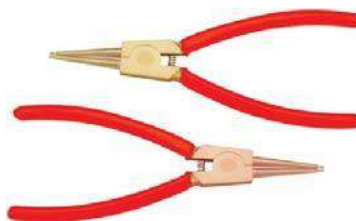

Number	L inch	L mm	Be-Cu g	Al-Cu g
257-1002 mm	8	200	290	265
257-1004	10	250	415	380

Bolt Chipper

No.257A



Number	L mm	D mm	Be-Cu g	Al-Cu g
257A-1002	600	6	3350	3070
257A-1004	900	8	9250	8400

Crimping Tool, Insulated Cable Connectors

No.257B

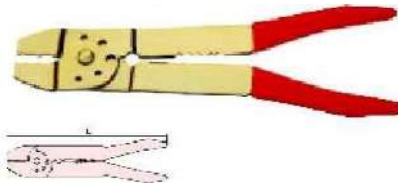

Number	L inch	L mm	Be-Cu g	Al-Cu g
257B-1002	8	200	225	205

Wire Stripping Pliers

No.257C

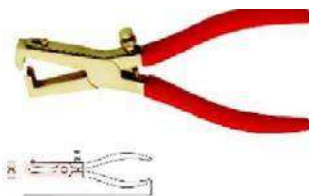

Number	L mm	Be-Cu g	Al-Cu g
257C-1002	170	225	205

Tweezers, Neat Tips

No.258

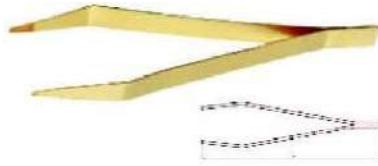

Number	L mm	Be-Cu g	Al-Cu g
258-1002	150	30	25
258-1004	200	50	40

Tweezers, Flat Nose

No.258A

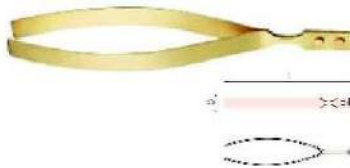

Number	L mm	B mm	Al-Cu g	Be-Cu g
258A-1002	100	8	30	25
258A-1004	200	15	65	55

Slotted Offset Screwdriver

No.259



Number	L mm	H mm	K mm	Be-Cu g	Al-Cu g
259-1002	72	1	6	25	23
259-1004	125	1.5	8	55	50
259-1006	196	1.5	10	135	124

Phillips Offset Screwdriver

No.259A



Number	L mm	Size	Be-Cu g	Al-Cu g
259A-1002	120	1#*2#	50	45

Slotted Screwdriver

No.260



Number	L1 inch	L1 mm	L mm	H mm	B mm	Be-Cu g	Al-Cu g
260-1002	2	50	134	0.4	3	35	33
260-1004	2	50	134	0.5	4.5	43	40
260-1006	3	75	159	0.4	3	35	32
260-1008	3	75	159	0.5	4	45	42
260-1010	3	75	180	0.6	5	70	65
260-1012	4	100	184	0.5	4	45	42
260-1014	4	100	205	0.6	5	75	70
260-1016	4	100	215	0.8	6	85	80
260-1018	5	125	240	0.8	6	100	95
260-1020	6	150	265	0.8	6	110	105
260-1022	6	150	265	1	7	125	120
260-1024	6	150	277	1.2	8	140	135
260-1026	8	200	327	1.2	8	165	155
260-1028	10	250	377	1.4	9	185	175
260-1030	10	250	377	2	11	260	245
260-1032	12	300	427	1.8	10	245	230
260-1034	12	300	427	2	11	290	275
260-1036	14	350	477	2	11	320	300
260-1038	16	400	550	2.4	12	450	430

**DAMAN INTERNATIONAL INDIA
NON SPARKING TOOLS**

Tel: 91-11-40521948 / 8076477394

E-Mail: akm4351@yahoo.co.in

Phillips Screwdriver

No.261



Number	L1 inch	Size	L1 mm	L mm	Φ mm	Be-Cu g	Al-Cu g
261-1002	2	0	50	134	3	35	32
261-1004	3	1	75	159	4	70	63
261-1006	4	1	100	205	5	75	70
261-1008	5	2	125	240	6	100	95
261-1010	6	2	150	265	6	110	105
261-1012	8	3	200	327	8	165	155
261-1014	10	3	250	377	8	185	170
261-1016	12	4	300	427	9	245	230
261-1018	14	4	350	477	9	270	255
261-1020	16	4	400	550	9	295	280
261-1022	18	4	450	600	9	320	300

Screwdriver

No.262



Number	L mm	L1 mm	B mm	Be-Cu g	Al-Cu g
262-1002	200	100	8	135	125
262-1004	250	110	8	220	204
262-1006	300	160	10	305	275
262-1008	500	350	11	505	461

**DAMAN INTERNATIONAL INDIA
NON SPARKING TOOLS**

Tel: 91-11-40521948 / 8076477394

E-Mail: akm4351@yahoo.co.

Slotted Screwdriver

No.263

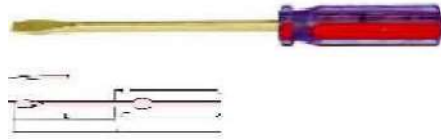

Number	L1 inch	L1 mm	L mm	H mm	B mm	Be-Cu g	Al-Cu g
263-1002	2	50	108	0.4	3	35	32
263-1004	3	75	133	0.5	3	48	44
263-1006	3	75	153	0.5	4	50	45
263-1008	3	75	153	0.6	5	51	46
263-1010	4	100	178	0.5	4	60	55
263-1012	4	100	178	0.6	5	71	65
263-1014	4	100	193	0.8	6	77	70
263-1016	6	150	243	1	7	115	105
263-1018	8	200	305	1.2	8	197	180
263-1020	10	250	355	1.4	9	221	202
263-1022	12	300	420	1.8	10	304	278
263-1024	14	350	470	2	11	365	335

Electrician Screwdriver

No.263A

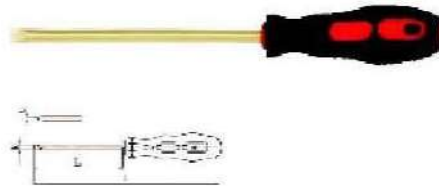

Number	L1 inch	L1 mm	L mm	H mm	B mm	Be-Cu g	Al-Cu g
263A-1002	2	50	134	0.4	3	37	35
263A-1004	4	100	184	0.5	4	47	45
263A-1006	4	100	215	0.8	6	95	90
263A-1008	6	150	277	1.2	8	145	135
263A-1010	8	200	327	1.8	10	230	210

Driver Hex Nut

No.263B

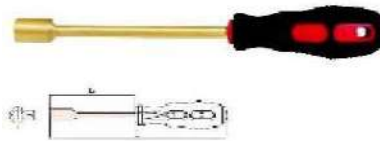

Number	L1 mm	L mm	S mm	Be-Cu g	Al-Cu g
263B-1002	90	205	6	85	81
263B-1004	100	215	8	100	85
263B-1006	110	225	10	140	130
263B-1008	110	237	13	185	172
263B-1010	120	247	16	220	205
263B-1012	120	247	17	230	218

Pozidriv Screwdriver

No.264

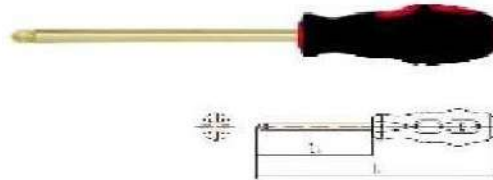

Number	L1 inch	Size	L1 mm	L mm	Be-Cu g	Al-Cu g
264-1002	2	0	50	134	35	33
264-1004	3	1	75	159	45	42
264-1006	4	2	100	220	85	80
264-1008	6	3	150	277	145	135
264-1010	8	4	200	327	230	210

Torx Screwdriver

No.264A



Number	Size	L1 mm	L mm	Be-Cu g	Al-Cu g
264A-1002	T10*75	75	180	70	63
264A-1004	T15*75	75	180	70	63
264A-1006	T20*100	100	215	100	95
264A-1008	T25*125	125	240	105	100
264A-1010	T30*150	150	265	110	100
164A-1012	T40*200	200	327	165	155
264A-1014	T45*250	250	377	185	175
264A-1016	T50*300	300	427	205	195
264A-1018	T55*350	350	477	245	225
264A-1020	T60*400	400	527	280	255

Screwdriver Bits

No.264B



Number	size
264B-	4.5mm,6.5mm,8mm
264B-	1#,2#,3#,4#
264B-	1#,2#,3#,4#
264B-	3mm,4mm,5mm,6mm,7mm,10mm
264B	T10,T15,T20,T25,T27,T30,T40

Insulated Slotted Screwdriver

No.265



Number	L1 inch	L1 mm	L mm	H mm	B mm	Be-Cu g	Al-Cu g
265-1002	2	50	134	0.4	3	35	33
265-1004	2	50	134	0.5	4.5	43	40
265-1006	3	75	159	0.4	3	35	32
265-1008	3	75	159	0.5	4	45	42
265-1010	3	75	180	0.6	5	70	65
265-1012	4	100	184	0.5	4	45	42
265-1014	4	100	205	0.6	5	75	70
265-1016	4	100	215	0.8	6	85	80
265-1018	5	125	240	0.8	6	100	95
265-1020	6	150	265	0.8	6	110	105
265-1022	6	150	265	1	7	125	120
265-1024	6	150	277	1.2	8	140	135
265-1026	8	200	327	1.2	8	165	155
265-1028	10	250	377	1.4	9	185	175
265-1030	10	250	377	2	11	260	245
265-1032	12	300	427	1.8	10	245	230
265-1034	12	300	427	2	11	290	275
265-1036	14	350	477	2	11	320	300
265-1038	16	400	550	2.4	12	450	430

Insulated Phillips Screwdriver

No.266

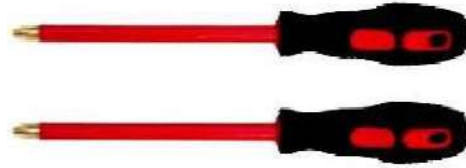

Number	L1 inch	size	L1 mm	L mm	Φ mm	Be-Cu g	Al-Cu g
266-1002	2	0	50	134	3	35	32
266-1004	3	1	75	159	4	70	63
266-1006	4	1	100	205	5	75	70
266-1008	5	2	125	240	6	100	95
266-1010	6	2	150	265	6	110	105
266-1012	8	3	200	327	8	165	155
266-1014	10	3	250	377	8	185	170
266-1016	12	4	300	427	9	245	230
266-1018	14	4	350	477	9	270	255
266-1020	16	4	400	550	9	295	280
266-1022	18	4	450	600	9	320	300

Marking Tool

No.267



Number	L mm	H mm	Φ mm	Be-Cu g	Al-Cu g
267-1002	400	40	12	502	445
267-1004	600	50	16	1152	1036

Marking Tool

No.268

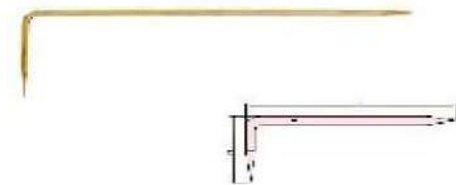

Number	L mm	H mm	Φ mm	Be-Cu g	Al-Cu g
268-1002	187	32	4	15	10
268-1004	252	42	4	20	15

Awl
No.269



Number	L1 inch	L1 mm	Φ mm	L mm	Be-Cu g	Al-Cu g
269-1002	4	100	3	184	50	45

Diriders
No.269A



Number	Dmax mm	H mm	Be-Cu g	Al-Cu g
269A-1002	200	200	170	150
269A-1004	400	400	400	360

Hacksaw Frame
No.270

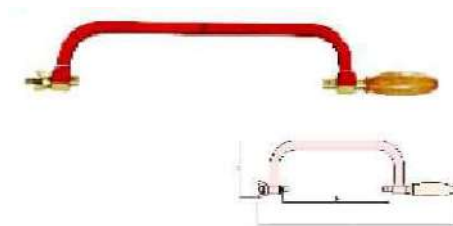

Number	L mm	D mm	H mm	Be-Cu g	Al-Cu g
270-1002	500	300	110	645	590

Hacksaw Blade

No.271



Number	L mm	B mm	Be-Cu g
271-1002	300	12	32

Hand Saw

No.272

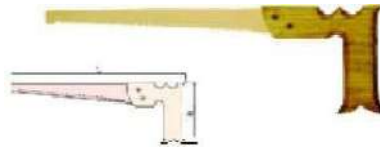

Number	L mm	H mm	Be-Cu g	Al-Cu g
272-1002	370	114	125	265

Hand Saw

No.272A

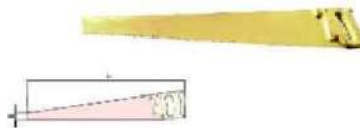

Number	L mm	B mm	Be-Cu g	Al-Cu g
272A-1002	700	35	555	520

DAMAN INTERNATIONAL INDIA

NON SPARKING TOOLS

Tel: 91-11-40521948 / 32955573

E-Mail: akm4351@yahoo.co.in

3 Leg Gear Puller

No.273

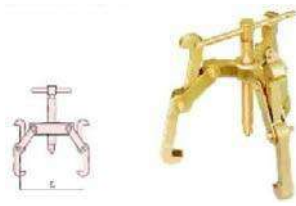

Number	Lmax mm	Be-Cu g	Al-Cu g
273-1002	100	3280	2990
273-1004	150	4050	3675
273-1006	200	5990	5430
273-1008	350	12350	11230

2 Leg Gear Puller

No.273A



Number	Lmax mm	Be-Cu g	Al-Cu g
273A-1002	100	2765	2500
273A-1004	150	3450	3120
273A-1006	200	5130	4640
273A-1008	350	10560	9545

Clamp

No.274

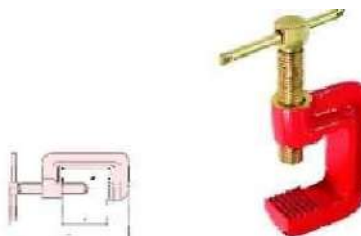

Number	L mm	K mm	B mm	Be-Cu g	Al-Cu g
274-1002	210	60	36	1200	1080
274-1004	250	80	36	1400	1270
274-1006	290	100	36	1610	1460
274-1008	340	150	50	2155	1970

Clamp
No.274A



Number	L mm	K mm	B mm	Be-Cu g	Al-Cu g
274A-1002	76	19	19	200	180
274A-1004	290	115	75	5600	5000
274A-1006	370	165	90	11100	10000

Fork, Three Prong
No.275



Number	L mm	B mm	H mm	Be-Cu g	Al-Cu g
275-1002	185	200	125	1690	1540

Fork, Four Prong
No.276

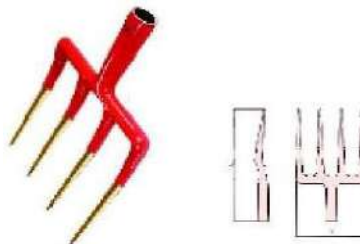

Number	L mm	B mm	Be-Cu g	Al-Cu g
276-1002	327	200	2150	1965

Cleaning Rust Rake

No.277

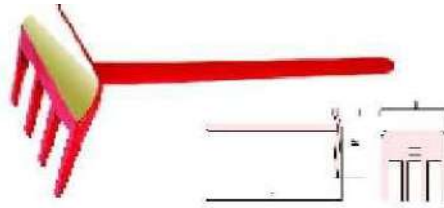

Number	L mm	H mm	B mm	Be-Cu g	Al-Cu g
277-1002	350	105	98	1050	950

Oil Funnel

No.278

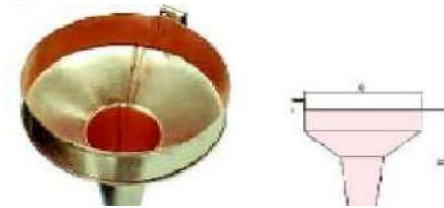

Number	Φ mm	H mm	Be-Cu g
278-1002	160	130	260
278-1004	160	150	280

Portable Oil Pump

No.279

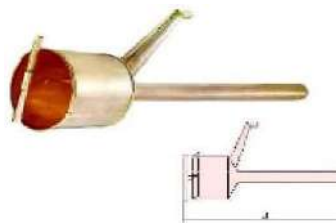

Number	Φ mm	H mm	Be-Cu g
279-1002	165	1100	2315

Oil Dipper
No.280

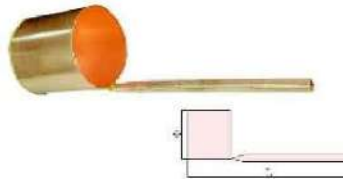

Number	Φ mm	H mm	Be-Cu g
280-1002	85	350	163

Bucket
No.281



Number	Φ mm	H mm	Be-Cu g
281-1002	270	248	1515

Dustpan
No.282



Number	L mm	B mm	H mm	Be-Cu g
282-1002	150	130	20	130
282-1004	200	200	50	335
282-1006	270	250	50	635

Scoop, Sugar
No.283



Number	L mm	H mm	Φ1 mm	Φ2 mm	Be-Cu g
283-1002	350	90	160	135	580

Scoop, Sugar
No.283A



Number	B mm	L mm	g
283A-1002	75	200	200
283A-1004	140	360	645

Scoop
No.283B



Number	Φ mm	L mm	Be-Cu g	Al-Cu g
283B-1002	112	500	1220	1100

Strainer
No.283C



Number	Φ mm	L mm	g
283C-1002	300	600	1800

Brush, Flat Back, Scratch
No.284

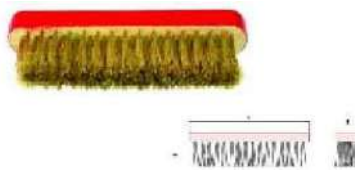

Number	L*B mm	Rows	H mm	g
284-1002	205*48	6*16	41	260

Brush
No.285



Number	L*B mm	Rows	H mm	g
285-1002	290*29	4*16	28	115

Brush
No.285A



Number	L*B mm	Rows	H mm	g
285-1002	350*28	4*19	30	150

**Brush
No.286**



Number	Block Size L*B mm	Rows	Trim Length H mm	g
286-1002	215*29	6*15	15	30

**Brush, Shoe Handle
No.286A**

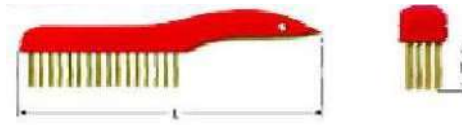

Number	L mm	Rows	Trim Length H mm	g
286A-1002	255	4*16	30	180

**Brush, Spark – Plug Cleaning
No.286B**

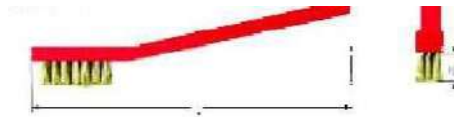

Number	L mm	Rows	Trim Length H mm	g
286B-1002	196	3*7	13	20

**Broom, Round Wire
No.286C**



Number	L mm	Rows	Trim Length H mm	g
286C-1002	310	6*25	55	1550

Scrubbing Broom, Round Wire

No.286D



Number	L mm	Rows	Trim Length H mm	g
286D-1002	210	6*17	40	500

Brush, Tube

No.287

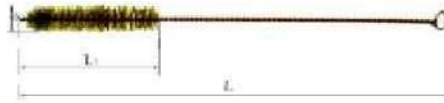

Number	Φ mm	L1 mm	L mm	g
287-1002	20	100	320	100

Brush, Wheel

No.288

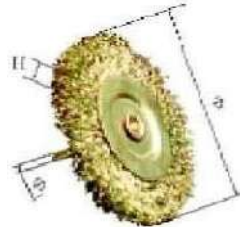

Number	Φ mm	H mm	Φ1 mm	g
288-1002	75	10	6	140

Wheel Brush, Knot Wire

No.289

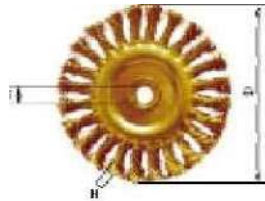

Number	Φ mm	H mm	M mm	g
289-1002	125	15	14	440

Brush, Wheel, Crimped Wire

No.289A

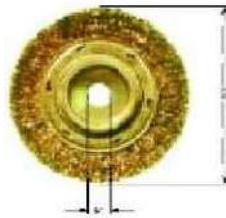

Number	Φ mm	H mm	M mm	g
289A-1002	125	15	14	320

Brush, Cup

No.290

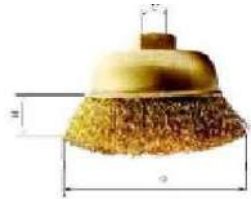

Number	Φ mm	H mm	M mm	g
290-1002	100	30	14	480

Cup Brush, Knot Wire

No.290A



Number	Φ mm	H mm	M mm	g
290A-1002	100	30	14	580

Brush, End

No.290B

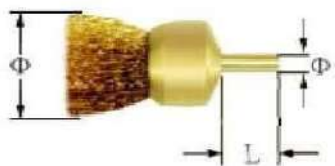

Number	Φ mm	L mm	Φ1 mm	G
290B-1002	26	25	6	120

Brush, Ball
No.290C



Number	g
290C-1002	25

Hoe
No.291



Number	B mm	H mm	Be-Cu g	Al-Cu g
291-1002	130	130	1080	970
291-1004	200	200	1780	1600

Shackle
No.292

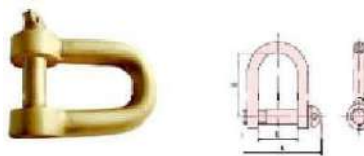

Number	Size	K mm	L mm	H mm	Be-Cu g	Al-Cu g
292-1002	1/2	30	60	40	135	130
292-1004	3/4	37	99	78	915	830

Manual Portable Oil Pump
No.293



Number	L mm	Be-Cu g	Al-Cu g
293-1002	1350	6000	5700

Barrel Hook, Adjustable
No.294

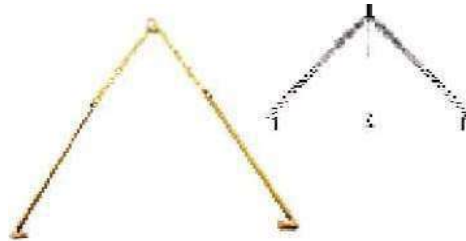

Number	H kg	K mm	Be-Cu g	Al-Cu g
294-1002	700	1060	3300	3050

Screw Clamp
No.295

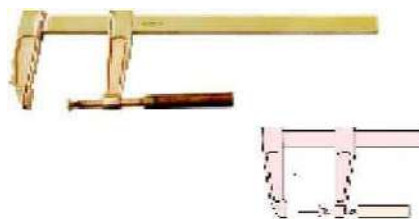

Number	Bmax mm	K mm	Be-Cu g	Al-Cu g
295-1002	120	400	2395	2200

Rake
No.296



Number	L mm	B mm	H mm	Be-Cu g	Al-Cu g
296-1002	1270	350	100	2080	1935
296-1004	1275	450	120	2300	2135

Chisel
No.297



Number	B mm	L mm	Be-Cu g	Al-Cu g
297-1002	14	280	200	180
297-1004	18	320	270	250

Rake
No.298



Number	B mm	H mm	Be-Cu g	Al-Cu g
298-1002	300	150	1550	1400

Rake
No.299



Number	L mm	B mm	H mm	Be-Cu g	Al-Cu g
299-1002	780	160	80	670	600

Fire Hook
No.300



Number	L mm	L1 mm	Be-Cu g	Al-Cu g
300-1002	270	1215	1365	1300

Self Locking Pipe Vice
No.301



Number	D mm	Be-Cu g	Al-Cu g
301-1002	10-60	4870	4425
301-1004	10-90	10350	9420
301-1006	15-115	15300	13900
301-1008	30-220	30600	27800
301-1010	30-300	38000	3500

Pipe Cutter
No.305



Number	D inch	D mm	Be-Cu g	Al-Cu g
305-1002	2	50	2210	2010
305-1004	3	75	4070	3700

Hydraulic Pallet Truck
No.306



Number	Load(kg)	L(mm)	H(mm)	B1(mm)	B2(mm)
306-1002	2000	1190	1240	160	545
h1(mm)	h2(mm)	Φ1(inch)	Φ2(inch)	Weight(kg)	
80	190	7	3	132	

Trolley For Chain Hoist
No.307



Size : FBGCL

Number	Capacity T	Lifting m	I-Beam Width m	kg
307-1002	0.5	2.5	68-94	16.5
307-1004	1	2.5	68-100	20
307-1006	2	2.5	94-124	26
307-1008	3	3	116-140	27.5
307-1010	5	3	142-180	34
307-1012	10	3	142-180	68
307-1014	16	3	142-180	170

Trolley For Chain Hoist (Push Type)

No.307A



Size : FBGCT

Number	Capacity T	I-Beam Width m	Kg
307A-1002	0.5	68-94	13
307A-1004	1	68-100	16.5
307A-1006	2	94-124	22
307A-1008	3	116-140	23.5

Trolley For Chain Hoist (Pull Type)

No.307B



Number	Capacity T	Lifting m	I- Beam Width m	Kg
307B-1002	0.5	2.5	68-94	12.5
307B-1002	1	2.5	68-100	14.5
307B-1002	2	2.5	94-124	22.3
307B-1002	3	3	116-140	24
307B-1002	5	3	142-180	34
307B-1002	10	3	142-180	68
307B-1002	16	3	142-180	170
307B-1002	20	3	142-180	170

Chain Hoist
No.308



Size : FBHS

Number	Capacity T	Lifting m	kg
308-1002	0.5	2.5	10.2
308-1004	1	2.5	13.6
308-1006	2	2.5	22
308-1008	3	3	23.6
308-1010	5	3	36
308-1012	10	3	68.5
308-1014	16	3	187

Chain Hoist
No.308A



Number	Capacity T	Lifting m	Kg
308A-1002	0.5	2.5	11.4
308A-1004	1	2.5	18.4
308A-1006	2	2.5	27.9
308A-1008	3	3	28.3
308A-1010	5	3	54

Ratchet lever Hoist

No.308B



Number	Capacity T	Lifting m	kg
308B-1002	0.75	1.5	7.7
308B-1004	1.5	1.5	11.8
308B-1006	3	1.5	21

Come Along

No.308C



Number	Lifting m	Kg
308B-1002	1	3
308B-1004	2	4.5
308B-1006	3	6.3

Torque Wrench

No.309



Number	C inch	Torque N.m	L mm	Be-Cu g	Al-Cu g
309-1002	3/8	100	310	600	540
309-1004	1/2	300	490	1340	1210
309-1006	3/4	500	560	2050	1930

Flange Prop

No.310



Number	Size mm	Be-Cu g	Al-Cu g
310-1002	FZM16-24	7300	6600
310-1004	FZM27-36	9900	9000

Separator

No.310A



Number	B mm	H mm	Be-Cu g	Al-Cu g
310A-1002	210	160	4500	4070

Parallel Vice

No.311



Number	B mm	Kmax mm	Be-Cu g	Al-Cu g
311-1002	90	90	8150	7400
311-1004	125	125	19550	16800
311-1006	150	150	30000	26500
311-1008	170	170	30300	27400

Chisel
No.311A



Number	K mm	L mm	Be-Cu g	Al-Cu g
311A-1002	50	165	915	830

Drill Bit
No.312



Number	Φ mm	L mm	Be-Cu g
312-1002	6	100	20
312-1004	7	120	30
312-1006	8	140	50
312-1008	9	160	75
312-1010	10	180	100
312-1012	11	200	120
312-1014	12	220	170
312-1016	13	240	220
312-1018	14	260	280
312-1020	15	280	360
312-1022	16	300	440
312-1024	17	300	500
312-1026	18	320	600
312-1028	19	320	700
312-1030	20	330	800

Releasing Static Device
No.313



Number	L mm	D mm	Al-Cu g
313-1002	1150	65	3700

Releasing Static Device

No.313A



Number	L mm	D mm	Al-Cu g
313A-1002	1150	65	3700

Releasing Static Device

No.313B



Number	L mm	D mm	Al-Cu g
313B-1002	1100	80	3600

Screw Jack

No.314



Number	Model	Capacity T	MIN.H m	Lifting m
314-1002	FBQL3.2	3.2	220	110
314-1004	FBQL 5	5	250	130
314-1006	FBQL10	10	280	150

314-1008

FBQL16

16

320

180

Packing tool

No.315



Number	Be-Cu g	Al-Cu G
315-1002	900	800

Double Open End Wrench Set

No.A



Tools	Description mm
Set- 9pcs	8*10,10*12,12*14,14*17,17*19, 19*22,22*24,24*27,30*32
Set- 10pcs	8*10,10*12,12*14,14*17,17*19, 19*22,22*24,24*27,27*30,30*32
Set- 11pcs	8*10,9*11,10*12,12*14,14*17,17*19, 19*22,22*24,24*27,27*30,30*32
Set- 13pcs	5.5*7,6*7,8*10,9*11,10*12,12*14, 14*17,17*19,19*22,22*24,24*27, 27*30,30*32

DAMAN INTERNATIONAL INDIA
NON SPARKING TOOLS
Tel: 91-11-40521948 / 8076477394
E-Mail: akm4351@yahoo.co.in

Combination Wrench Set

No. B



Tools	Description mm
Set- 9pcs	8,10,12,14,17,19,22,24,27
Set- 10pcs	10,12,14,17,19,22,24,27,30,32
Set- 11pcs	8,10,12,14,17,19,22,24,27, 30,32
Set- 13pcs	8,10,12,13,14,16,17,19,22,24, 27,30,32

Double Box Offset Wrench Set

No. C



Tools	Description mm
Set- 9pcs	8*10,10*12,12*14,14*17,17*19, 19*22,22*24,24*27,30*32
Set- 10pcs	8*10,10*12,12*14,14*17,17*19, 19*22,22*24,24*27,27*30,30*32
Set- 11pcs	8*10,9*11,10*12,12*14,14*17,17*19, 19*22,22*24,24*27,27*30,30*32
Set- 13pcs	5.5*7,6*7,8*10,9*11,10*12,12*14, 14*17,17*19,19*22,22*24,24*27, 27*30,30*32

Drill Bit Set – 15pcs

No. D



Tools	Description mm
Drill Bit	6*100mm,7*120mm, 8*140mm,9*160mm, 10*180mm,11*200mm, 12*220mm,13*240mm, 14*260mm,15*280mm, 16*300mm,17*300mm, 18*320mm,19*320mm 20*330mm

Tool Set – 9pcs

No. E



L*W*H: 400*290*90mm

Tools	Description mm
Wrench,Adjustable	300mm
Pliers,Lineman	200mm
Pliers,Groove Joint	250mm
Slotted Screwdriver	150mm,200mm
Phillips Screwdriver	150mm,200mm
Hammer,Cross Pein Knife,Putty	1kg
Knife,Putty	50mm*200mm

Tool Set – 15pcs

No. F



L*W*H:400*290*90mm

Tools	Description mm
Wrench,Double Open End	12*14mm,14*17mm, 17*19mm,19*22mm, 22*24mm.24*27mm, 30*32mm
Wrench,Adjustable	250mm
Pliers,Lineman	200mm
Pliers,Snipe Nose	200mm
Slotted Screwdriver	200mm
Phillips Screwdriver	200mm
Hammer,Ball Pein	0.91kg

DAMAN INTERNATIONAL INDIA

NON SPARKING TOOLS

Tel: 91-11-40521948 / 8076477394

E-Mail: akm4351@yahoo.co.in

Tool Set – 16pcs

No. G



Tools	Description mm
Wrench,Double Box	8*10, 10*12, 14*17, 19*22mm
Wrench,Adjustable	250mm
Wrench,Pipe	350mm
Pliers,WaterPump	250mm
Pliers,Adjustable,Combination	150mm,200mm
Slotted Screwdriver	150mm
Phillips Screwdriver	150mm
Hammer,Claw	0.45kg
Knife,Putty	25*200mm
Knife,Common	250mm
Scraper,Deck	45*300mm
Brush	4*16mm

**DAMAN INTERNATIONAL INDIA
NON SPARKING TOOLS**

Tel: 91-11-40521948 / 8076477394

E-Mail: akm4351@yahoo.co.in

Tool Set – 17pcs

No. H



Tools	Description mm
Wrench,Pipe	350mm
Wrench,Adjustable	200mm,300mm
Wrench,Combination	14mm,17mm,19mm, 22mm,24mm,27mm
Pliers,Lineman	200mm
Pliers,Long Nose	200mm
Pliers,Adjustable Combination	200mm
Punch,Machinists	Φ18*160mm
Chisel,Flat	Φ18*160mm
Slotted Screwdriver	150mm
Phillips Screwdriver	150mm
Hammer,Ball Pein	0.91Kg

Tool Set – 26pcs

No.1



L*W*H:370*270*95mm

Tools	Description mm
Chisel Flat	18*180mm
Wrench,Adjustable	150mm
Pliers,Lineman	200mm
Pliers,Adjustable	
Combination	200mm
Pliers,Snipe Nose	150mm
Phillips Screwdriver	150mm,200mm
Slotted Screwdriver	150mm,200mm
Socket(1/2 ")Dr	8mm,10mm,12mm,14mm, 17mm
Sliding T Handle	1/2 " *250mm
Hammer,Testing	0.15kg
Wrench,Combination	8mm,10mm,12mm,14mm, 17mm
Wrench,Hex Key	4mm,5mm,6mm,8mm,10mm

Tool Set – 26pcs

No.J



L*W*H:650*400*140mm

Tools	Description mm
Wrench,Pipe	450mm,250mm
Wrench,Adjustable	375mm,300mm
	200mm,150mm
Hammer,Ball Pein	0.91kg
Pliers,Lineman	200mm
Pliers,Snipe Nose	200mm
Slotted Screwdriver	400mm,200mm
Phillips Screwdriver	400mm,200mm
Valve Handle	500mm
Wrench,Double Box	30*27mm,27*24mm,24*22mm, 22*19mm,19*17mm,17*14mm
Wrench,Double Open End	30*32mm,27*30mm,24*27mm, 22*24mm,19*22mm,17*19mm

Tool Set – 28pcs

No.K



Tools	Description mm
Hammer,Sledge	1.8kg
Hammer,Ball Pein	0.91Kg
Hammer,Claw	0.45kg
Wrench,Pipe	300mm,450mm
Wrench,Adjustable	200mm,300mm
Wrench,Combination	8mm,10mm,12mm, 14mm,17mm,19mm, 22mm,24mm, 27mm,30mm,32mm
Pliers,Lineman	200mm
Pliers,Long Nose	200mm
Pliers,Adjustable Combination	200mm
Bar,Pinch	Φ25*300mm
Chisel,Flat	Φ25*300mm
Slotted Screwdriver	100mm,200mm
Phillips Screwdriver	100mm,200mm
Valve Handle	400mm

Tool Set – 36pcs

No.L



Tools	Description mm
Hammer,Sledge	1.8kg
Hammer,Ball Pein	0.91kg
Wrench,Pipe	450mm
Wrench,Adjustable	150mm,200mm
Wrench,Combination	10mm,8mm
Pliers,Lineman	200mm,150mm
Pliers,Snipe Nose	150mm
Pliers,Adjustable,Combination	200mm
Pliers,Round Nose	150mm
Pliers,Flat Nose	150mm
Pliers,Diagonal Cutting	150mm
Slotted Screwdriver	75mm,100mm, 150mm, 200mm
Phillips Screwdriver	75mm,100mm, 150mm, 200mm
Slotted Offset Screwdriver	6*72mm,8*125mm, 10*196mm
Chisel 8 Point	16*160mm
Shears,Cutting	150mm
Knife,Common	250mm
Knife,Putty	50*200mm
Tweezers,Neat Tips	200mm
Bar	19*500mm
Marking Tool	250mm
Bar,Wrecking	400mm
Hacksaw Frame	500mm
Hacksaw Blade	300mm
Brush,FlatBack,Scratch	6*16mm

Tool Set – 40pcs

No.M



Tools	Description mm
Hammer,Sledge	1kg
Hammer,Claw	0.23kg
Hammer,Ball Pein	0.45kg
Wrench,Pipe	200mm
Wrench,Adjustable	150mm,250mm
Pliers,Lineman	150mm
Pliers,Snipe Nose	150mm
Pliers,Flat Nose	150mm
Pliers,Diagonal Cutting	150mm
Pliers,Adjustable,Combination	150mm
Pincers	200mm
Shears,Cutting	150mm
Slotted Screwdriver	75mm,100mm,150mm
Phillips Screwdriver	75mm,100mm,150mm,
Slotted Offset Screwdriver	6*72mm,8*125mm,10*196mm
Wrench,Hex Key	3mm,4mm,5mm,6mm,7mm,8mm
Chisel,6 Point	16*160mm
Bar,Wrecking	250mm
Knife,Common	250mm
Knife,Putty	25*200mm
Tweezers,Neat Tips	150mm
File,Triangle	200mm
Hearing Needle	6*250mm
Marking Tool	250mm
Hand Saw	370mm
Hacksaw Frame	500mm
Hacksaw Blade	300mm
Brush	6*16mm

Tool Set – 56pcs

No.N



Tools	Description mm
Wrench,Double Open End	5.5*7,6*7,8*10,9*11,10*12.12*14,14*17, 17*19,19*22,22*24,24*27,27*30,30*32mm
Wrench,Hex Key	2mm,3mm,4mm,5mm,6mm,7mm,8mm, 10mm
Slotted Screwdriver	50mm,75mm,100mm,150mm
Phillips Screwdriver	50mm,75mm,100mm,150mm
Wrench,Adjustable	250mm
Tweezers,Neat Tips	150mm
Pliers,Lineman	150mm
Pliers,Snipe Nose	150mm
Pliers,Groove Joint	250mm
Torque Wrench	1/4",3/8"
1/4"Socket	4mm,5mm,6mm,7mm,8mm,9mm,10mm, 11mm
3/8"Socket	10mm,11mm,12mm,13mm,14mm,17mm, 19mm
Driver Type Handle	1/4"
Ratchet Wrench	3/8"
Straight Joint	3/8"
Driver Extension	3/8"*75mm
Spark Plug	

Tool Set – 50pcs

No.0



Tools	Description mm
Hammer,Sledge	1.8kg
Hammer,Ball Pein	0.91kg
Hammer,Claw	0.45kg
Wrench,Pipe	300mm,450mm
Wrench,Adjustable	200mm*24mm,300mm*36mm
Wrench,Combination	8mm,10mm,12mm,14mm, 17mm,19mm,22mm,24mm, 27mm,30mm,32mm
Pliers,Lineman	200mm
Pliers,Long Nose	200mm
Pliers,Adjustable Combination	200mm
Bar,Pinch	Φ25*300mm
Chisel,Flat	Φ25*300mm
Punch,Machinists	Φ20*300mm
Slotted,Screwdriver	100mm,200mm
Phillips,Screwdriver	100mm,200mm
Valve,Handle	400mm
Knife,Common	250mm
Hacksaw Frame	500mm
Hacksaw Blade	300mm
1/2"Socket	10mm,11mm,12mm,14mm, 17mm,19mm,22mm,24mm, 27mm,30mm,32mm
Ratchet Wrench	250mm
Driver Extension	125mm,250mm
Speed Handle	400mm
Sliding T Handle	250mm
Universal Joint	1/2"
Putty Knife	25*200mm

Tool Set – 62pcs

No. P



Tools	Description mm
Wrench,Adjustable	200mm,250mm,300mm
Wrench,Combination	8mm,10mm,12mm,14mm, 17mm,19mm,22mm,24mm, 27mm
Wrench,Combination	3/8", 1/2", 9/16", 5/8", 11/16", 3/4", 13/16", 7/8", 1"
Wrench,Pipe	200mm,350mm
Pliers,Groove Joint	250mm
Pliers,Adjustable,Combination	150mm,200mm,
Pliers,Lineman	200mm
Pliers,Snipe Nose	150mm
Slotted Screwdriver	75mm,100mm,150mm,200mm,
Phillips Screwdriver	75mm,100mm,150mm,200mm,
Bar,Wrecking	400mm
Bar,Pinch	Φ19*500mm
Knife,Common	250mm
Knife,Putty	40*200mm,50*200mm, 100*200mm
Scraper,Deck	350mm
Wrench,Bung	385mm
Chisel,Flat	16*160mm,18*200mm
Hammer,Cross Pein Engineers	0.5kg,1kg
Hammer,Claw	0.45kg
1/2"Socket	8mm,10mm,13mm,14mm, 16mm.17mm,19mm,21mm, 22mm,26mm
Driver Extension	200mm
Ratchet Wrench	245mm
Hinged Handle	250mm

Tool Set – 100pcs

No.Q



L*W*H:625*375*745mm

Tools	Description mm
Hammer,Ball Pein	0.23kg,0.45kg
Hammer,Claw	0.23kg
Wrench,Adjustable	150mm,200mm, 250mm
Wrench,Combination	8mm,10mm,12mm,14mm, 17mm,19mm,22mm,24mm, 27mm,30mm,32mm
Pliers,Lineman	200mm
Pliers,Snipe Nose	150mm
Pliers,Adjustable Combination	150mm
Pliers,Flat Nose	150mm
Pincers	200mm
Pliers,Round Nose	150mm
Pliers,Diagonal Cutting	200mm
Tweezer,Neat Tips	150mm
Flat 6 Chisel	14*160mm,16*160mm,18*160mm
Centre Punch	Φ16*100mm,Φ18*200mm, Φ20*300mm
Punch,Machinists	Φ18*160mm,Φ18*250mm, Φ20*300mm
Slotted Screwdriver	5*75mm,6*100mm,7*150mm, 8*200mm,9*300mm,10*350mm
Phillips Screwdriver	5*75mm,6*150mm,8*250mm, 9*300mm
Knife,Common	250mm
Hacksaw Frame	500mm
Hacksaw Blade	300mm
Hand Saw	370mm
Scraper,Flat	35*350mm
File,Half Round With Handle	200mm
File,Flat With Handle	200mm
File,Square With Handle	200mm
File,Triangle With Handle	200mm
1/4"*3/8"Socket	Set-20pcs
3/4"*1"Socket	Set-26pcs
Torch	2"

Tool Set – 120pcs

No.R



Tools	Description mm
Wrench,Combination	8mm,10mm,12mm,13mm,14mm,16mm, 17mm,19mm,22mm,24mm,27mm, 30mm,32mm
Valve Handle	400mm
Hammer,Sledge	1kg, 1.8kg
Hammer,Claw	0.45kg
Hammer,Ball Pein	0.45kg
Wrench,Pipe	150mm,200mm,250mm,300mm,350mm
Wrench,Adjustable	150mm,200mm, 250mm,300mm
Pliers,Lineman	150mm,200mm
Pliers,Snipe Nose	150mm,200mm
Pliers,Flat Nose	150mm,200mm
Pliers,Diagonal Cutting	150mm,200mm
Pliers,Adjustable,Combination	150mm,200mm
Pincers	200mm
Shears,Cutting	150mm
Pliers,Groove Joint	250mm
Slotted Screwdriver	75mm,100mm,150mm,200mm
Phillips Screwdriver	75mm,100mm,150mm,200mm
Slotted Offset Screwdriver	6*72mm,8*125mm,10*196mm
Wrench,Hex Key	3mm,4mm,5mm,6mm,7mm,8mm,10mm
Chisel 6 Point	16*160mm
Bar,Wrecking	250mm
Wrench,Bung	350mm
Knife,Common	250mm
Knife,Putty	25*200mm
Tweezers,Neat Tips	150mm
File,Triangle	200mm
Hearing Needle	6*250mm
Marking Tool	250mm
Hand Saw	370mm
Hacksaw Frame	500mm
Hacksaw Blade	300mm
Brush	6*16mm
1/2"Dr Socket	Set-28pcs
3/4"Dr Socket	Set-21pcs

Tool Set – 176pcs

No.S



Tools	Description mm	Quantity
Wrench,Combination	6mm,8mm,10mm, 12mm, 13mm,14mm,15mm,16mm, 17mm,19mm,22mm,24mm, 27mm,30mm,32mm	2
Wrench,Single Open End	41mm,42mm,44mm,46mm, 48mm,50mm,55mm,60mm	2
Wrench,Double Open End	8*10mm,9*11mm,12*14mm, 13*16mm,16*18mm,17*19mm 20*22mm,21*23mm,24*27mm 30*32mm	2
Wrench,Socket L-Type	8mm,10mm,12mm,13mm, 14mm,15mm,16mm,17mm 19mm,22mm,24mm,27mm, 30mm,32mm	2
Wrench,Hex Key	8mm,10mm,12mm,13mm, 14mm,17mm,19mm,22mm	2
Wrench,Adjustable	200mm,300mm	2
Slotted Screwdriver	100mm,150mm,200mm	2
Phillips Screwdriver	100mm,150mm,200mm	2
Pliers,Lineman	200mm	2
Pliers,Groove Joint	250mm	2
Wrench,Striking Box	22mm,24mm,27mm,30mm, 32mm,34mm,36mm,38mm, 41mm,46mm,50mm,55mm, 60mm,65mm,70mm,	2
Chisel,Hex 6 Point	14*160mm	3
Punch,Machinists	14*150mm	3
Brush,Flat Back,Scratch	205*48mm	3
Brush	290*29mm	3
Hammer,Sledge	1kg,1.8kg,2.7kg,4.5kg	1